

# SL3ICS3001

## UCODE HSL

Rev. 3.1 — 9 July 2012  
072831

Product data sheet  
COMPANY PUBLIC

## 1. General description

---

The UCODE HSL IC, SL3ICS3001 (UCODE High frequency Smart Label) is a dedicated chip for passive smart tags and labels, especially for supply chain management and logistics applications in the US, where operating distances of several meters can be realized. Further, the UCODE HSL technology platform is also designed for operation under European regulations.

This integrated circuit is the first member of a product family of smart label ICs targeted to be compliant with the future ISO standards 18000-4 and 18000-6 for item management.

The UCODE HSL system offers the possibility of operating labels simultaneously in the field of the interrogator antenna (Anticollision, Collision Arbitration).

The UCODE HSL family of ICs is especially designed for long range applications.

The tag requires no internal power supply. Its contactless interface generates the power supply via the antenna circuit by propagative energy transmission from the interrogator (read/write device), while the system clock is generated by an on-board oscillator. The contactless interface demodulates data transmitted from the interrogator to the UCODE HSL based tag, and further modulates the electromagnetic field provided by the interrogator for data transmission from the UCODE HSL based tag to the interrogator.

A generic RFID system consists of an interrogator (base station) that runs the RFID protocol, as well as one or more tags. The tag itself includes an SL3ICS3001 chip and an antenna tuned to the carrier frequency of the interrogator, and a package to hold the chip and antenna together.

When placed in the RF field of an interrogator, a SL3ICS3001 based tag will begin to power up. If the field is strong enough, the tag IC will execute a power-on reset and will be ready to receive commands. Each command begins with a preamble and start delimiter that, taken together, enable the tag to perform clock and data recovery on the incoming signal. Data to and from the tag is checked for errors using a CRC. Therefore, CRC fields are present in all interrogator commands and in all tag responses. Additional data protection is provided by Manchester encoding on the forward (interrogator to tag) link and FM0 encoding on the return (tag to interrogator) link.

The interrogator can perform a number of functions on tags in its field. For example, the interrogator can send a command sequence, which allows it to identify multiple tags in its RF field simultaneously. Alternatively, it can select a subset of the tags in the field based on tag memory contents. It can also read data stored on a tag in its field, as well as write data to such a tag. In addition, it can simultaneously write data to an arbitrary subset of the tags in the field.



Signals enter the chip through the RF front end, where both tag power and the modulation envelope are recovered. Tag power is regulated and bias voltages are generated in one part of the analog section. In another part of the analog section, the modulation envelope is applied to a clock and data recovery circuit. In the case of a valid command, the first part of the input signal is the preamble and start delimiter, which will be followed by a specific tag command and any additional fields that command may require. All valid digital data is processed in the digital section data path, which is controlled by the digital control module. If a read or write is to be executed, the EEPROM block will be accessed. If data is to be sent from the tag to the interrogator in response to the command, the digital section sends the output pattern back to the RF front end, where the impedance modulation that constitutes backscatter is executed.

## 2. Features and benefits

### 2.1 RF interface features

- Contactless transmission of data and supply energy (no battery needed)
- Operating distance, depending on antenna geometry and local regulations, up to 8.4 m for a single antenna
- Operating frequency within the released operating bands from 860 MHz to 960 MHz and from 2.4 GHz to 2.5 GHz
- High data integrity: 16 bit CRC, framing
- True anticollision for collision arbitration
- Write distance is 70% of reading distance

### 2.2 Memory features

- 2048 bits including lock bits
- 64 bits UID in memory bytes 0 to 7
- 216 bytes with user definable access conditions for memory bytes 8 to 223

### 2.3 Security features

- Unique serial number for each device
- Lock mechanism (write protection) for each byte

### 2.4 Operating distances features

RFID tags based on the SL3ICS3001 silicon may achieve operating distances according the following formula:

$$P_{tag} = EIRP \cdot G_{tag} \cdot \left(\frac{\lambda}{4\pi R}\right)^2$$

$P_{TAG}$  ... minimum required RF power for the tag

$G_{TAG}$  ... Gain of the tag antenna

EIRP ... Transmitted RF power

$\lambda$  ... wavelength

$$R_{max} = \sqrt{\frac{EIRP \cdot G_{TAG} \cdot \lambda^2}{(4\pi)^2 \cdot P_{TAG}}}$$

$R_{max}$  ... maximum achieved operating distance for a lossless, matched  $\lambda/2$ -dipole.

The maximum write distance is around 70% of the read distance.

**Table 1. Operating distances for UCODE HSL based tags and labels in released frequency bands**

Frequency range	Region	Available power	Calculated read distance single antenna <sup>[8][9]</sup>	Unit
868.4 to 868.65 MHz (UHF)	Europe <sup>[1]</sup>	0.5 W ERP	4.0	m
865.5 to 867.6 MHz (UHF)	Europe <sup>[2]</sup>	2 W ERP	8.0	m
902 to 928 MHz (UHF)	America <sup>[3]</sup>	4 W EIRP	8.4	m
860 to 930 MHz (UHF)	Others <sup>[4]</sup>			m
2.400 GHz to 2.4835 GHz	Europe <sup>[5]</sup>	0.5 W EIRP outdoor	0.6	m
2.400 GHz to 2.4835 GHz	Europe <sup>[5]</sup>	4 W EIRP indoor	1.8	m
2.400 GHz to 2.4835 GHz	America <sup>[6]</sup>	4 W EIRP	1.8	m
2.400 GHz to 2.4835 GHz	Others <sup>[7]</sup>			m

[1] Current CEPT/ETSI regulations [CEPT1], [ETSI1].

[2] Proposal for future CEPT/ETSI regulations.

[3] FCC regulation [FCC1].

[4] In many other countries regulations either similar to FCC or CEPT/ETSI may apply.

[5] Current CEPT/ETSI regulations [CEPT2], [ETSI2].

[6] FCC regulation [FCC1].

[7] In many other countries regulations either similar to FCC or CEPT/ETSI may apply.

[8] These distances are typical values for general tags and labels. A special tag antenna design or reflection could achieve higher values.

[9] Practical usable read distance values may be notable lower, strongly depending on application set-up, damping by environment materials and the quality of the matching between tag antenna and chip impedance.

The maximum write distance is around 70% of the read distance.

## 2.5 Air interface standards

The SL3ICS30 is fully supporting standardization on air interfaces. The SL3ICS30 is targeted to be compliant with the following air interfaces:

- ISO 18000-4
  - ◆ Information Technology - Radio Frequency Identification (RFID) for Item Management - Part 4: Parameters for Air Interface Communications at 2.45 GHz
- ISO 18000-6
  - ◆ Information Technology - Radio Frequency Identification (RFID) for Item Management - Part 6: Parameters for Air Interface Communications at 860 - 930 MHz
- ANSI/INCITS 256-2001
  - ◆ Radio Frequency Identification (RFID) Part 3 - 2.45 GHz
- ANSI/INCITS 256-2001
  - ◆ Radio Frequency Identification (RFID) Part 4 - UHF

## 2.6 Application standards

The SL3ICS30 is also fully supporting application standardization. The SL3ICS30 is targeted to be compliant with the following application standards:

- MH10.8.4
  - ◆ Radio Frequency Identification for Returnable Containers and Cable Reels
- AIAG B-11
  - ◆ Automotive Tire and Wheel Label Radio Frequency (RFID) Identification Standard
- EAN.UCC GTAG™
  - ◆ Global tag initiative
- ISO 18185
  - ◆ Freight Containers - Radio-frequency communication protocol for electronic seal

## 3. Applications

- Asset management
- Supply chain management
- Item level tagging
- Container identification
- Pallet and case tracking
- Product authentication
- Windshield tagging

## 4. Ordering information

Table 2. Ordering information

Type number	Package		Version
	Name	Description	
SL3ICS3001FW/V7	Wafer	Bumped die on sawn wafer	-

## 5. Block diagram

The SL3ICS3001 IC consists of three major blocks:

- Analog RF Interface
- Digital Controller
- EEPROM

The analog part provides stable supply voltage and demodulates data received from the interrogator for processing by the digital part. Further, the modulation transistor of the analog part transmits data back to the interrogator.

The digital section includes the state machines, processes the protocol and handles communication with the EEPROM, which contains a unique ID and user data.

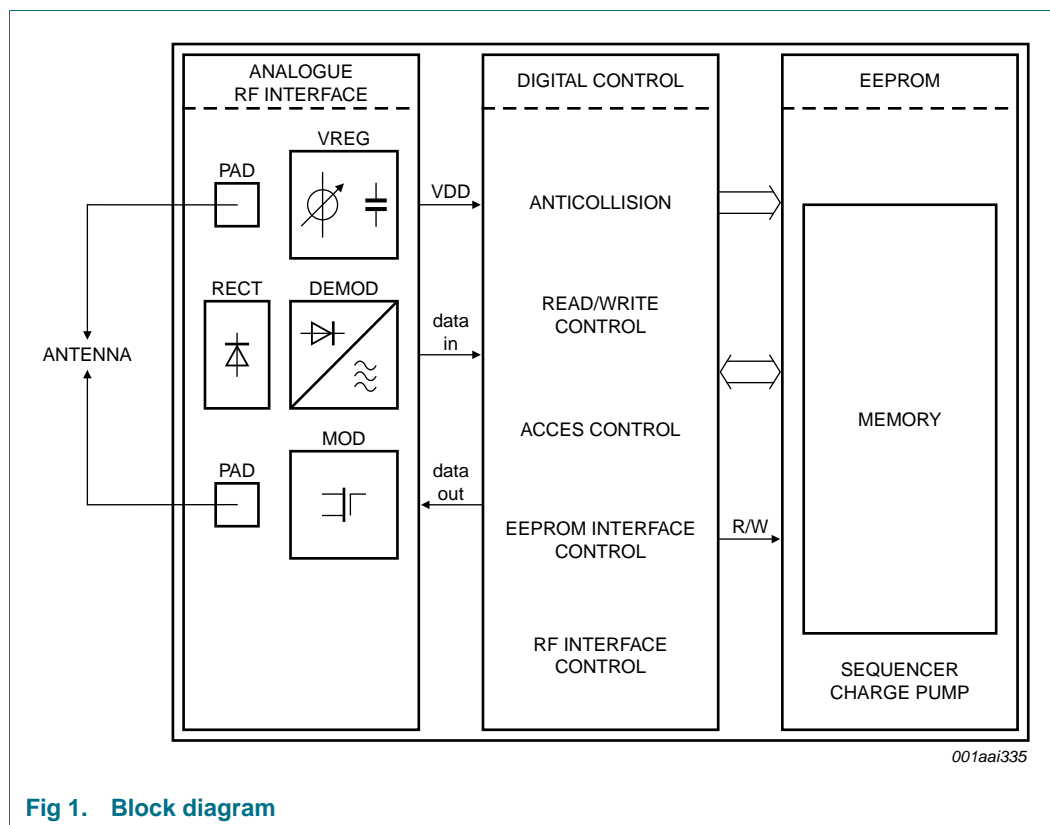

Fig 1. Block diagram

## 6. Pinning information

For pinning details please refer to [Ref. 7 "Data sheet addendum"](#).

## 7. Functional description

### 7.1 Power transfer

The interrogator provides a RF field that powers the tag containing the SL3ICS3001 and an antenna. The tag antenna transforms the impedance of free space to the chip input impedance in order to get the maximum possible power for the SL3ICS3001 on the tag.

The RF field, which is oscillating on the operating frequency provided by the interrogator, is rectified to provide smoothed DC voltage to the analog and digital modules of the IC.

The antenna that is attached to the chip has to support the rectifier structure on the chip by having no short circuit between the two antenna connectors (e.g. simple dipole structure). There will appear a DC voltage on the chip inputs during chip operation.

The RF field has to be turned on whenever the tag should operate. This also includes response time (backscatter) and the EEPROM programming process.

### 7.2 Operation frequency

The SL3ICS3001 supports global operation in different frequency bands. In principle, the SL3ICS3001 has no restriction on the operating frequency. Based on regulation requirements the SL3ICS3001 is released for the following frequency bands.

**Table 3. Released operating frequency bands**

Frequency band	Limit		Unit
	Lower	Upper	
UHF	860	960	MHz
2.45 GHz	2.4	2.5	GHz

### 7.3 Data transfer

#### 7.3.1 Forward link

The SL3ICS3001 supports Manchester Code amplitude modulation. For data transmission, the interrogator switches between two values of emitted power.

Details are described in [Section 9](#).

#### 7.3.2 Return link

As the energy of the RF field is used and required for operation, the tag communicates back to the interrogator by changing its load to the RF field. For high frequencies, the behaviour of the RF field (electromagnetic field) may be described by travelling waves. Therefore, this method is called backscatter.

Details are described in [Section 9](#).

## 8. Protocol

### 8.1 Major digital states

A powered IC can be in three major digital states:

- **READY** the reset state when the tag is first powered up
- **ID** the tag is trying to identify itself to the base station
- **DATA EXCHANGE** the tag is known to the base station

In a typical application a tag will first be powered and set to the READY state. By a select command, the IC will participate in an anticollision sequence that will be processed in the ID state. If the tag gets identified a read command will typically move it to the DATA EXCHANGE state, where further read, write or lock commands can be performed.

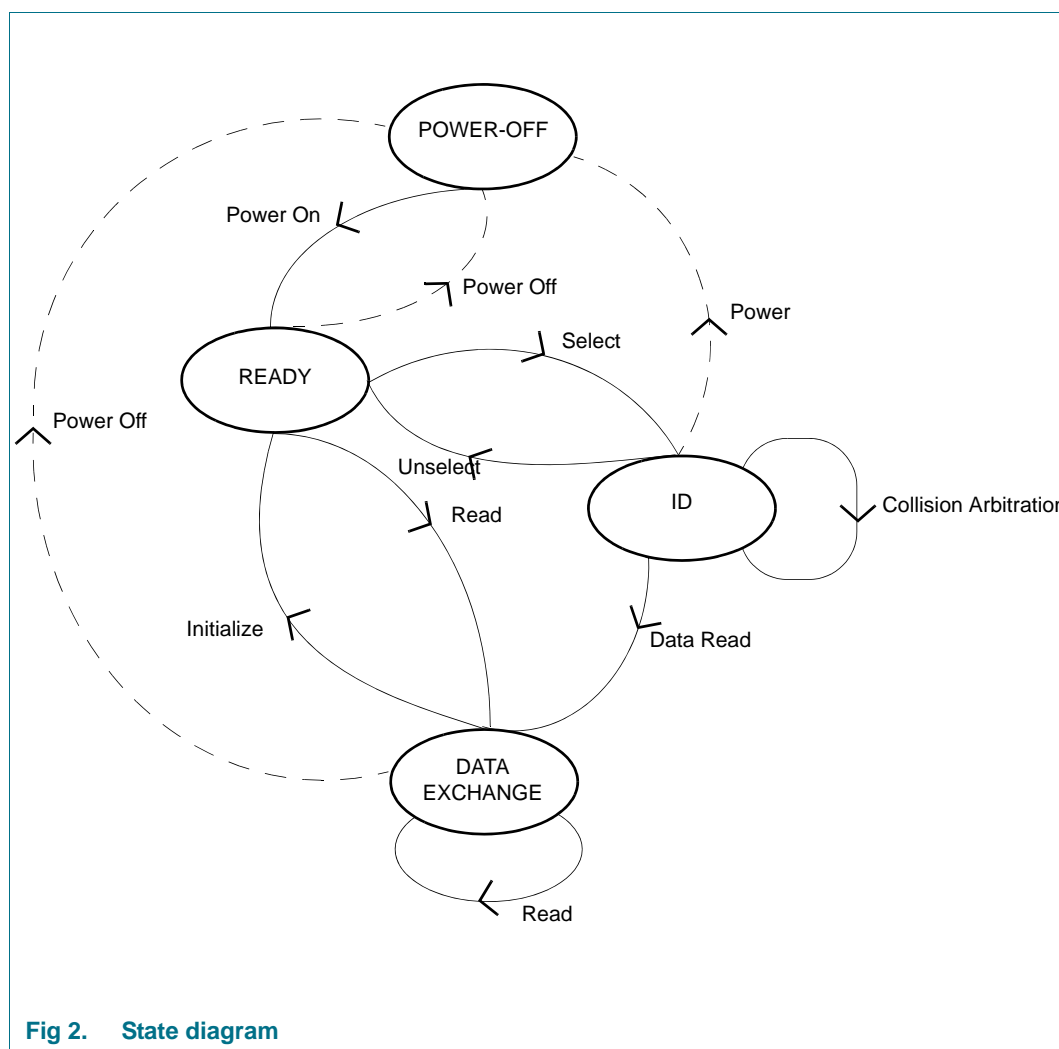

### State transition description

- Power-On
  - state change when interrogator field is turned on
- Power-Off
  - state change when interrogator field is turned off
- Select
  - state change due to selection of tag by GROUP\_SELECT commands
- Unselect
  - state change due to deselection of tag by GROUP\_UNSELECT commands
- Data\_Read
  - state change due to first read access in collision arbitration process
- Read
  - state change due to read access independent of collision arbitration process
- Initialize
  - state change due to deselection of all tags by the INITIALIZE command

As the state machine only supports 3 active states (READY, ID and DATA\_EXCHANGE), only 3 opportunities of the tag status exist when the tag comes into the ready state after the power-off state.

1. The tag is new in this environment or was out of the field for a long while. In this case the tag should stay in the ready state until a new collision arbitration loop is initiated by a GROUP\_SELECT command.
2. The tag has been participating in a collision arbitration and lost power through field nulls or just came out of the operating range. In this case, the tag has lost one or more collision arbitration commands and should therefore no longer participate in the active collision arbitration round. It should stay in the ready state until a new collision arbitration loop is initiated by a GROUP\_SELECT command.
3. The tag had been selected already and was powered-down due to field nulls or short time being out of the operating range. In this case the tag no longer needs to be considered in the collision arbitration loops of this interrogator. Interrogators using the GROUP\_SELECT\_FLAG and GROUP\_UNSELECT\_FLAG commands appropriately do not need to handle tags with DE\_SB set and therefore limit the number of tags for the next collision arbitration loop to only those tags that have not been handled before.

By use of above mechanism each field null shorter than  $t_{DE\_SB}$ , which is at least several seconds does not require a tag to be handled more than once in the collision arbitration. In general the use of the DE\_SB bit improves the number of tags identified within a certain time especially for large tag numbers when field nulls exist.

The exact transition between these states is specified in [Table 5](#).



## 8.2 Command overview

Table 4. Command Overview

Command name	State <sup>[1]</sup>			Description
	R	I	D	
GROUP_SELECT_xx <sup>[2]</sup>	x	x		group of commands that selects a class of tags in the field to participate in the identification process; selection criteria is the data at a specified address
GROUP_UNSELECT_xx <sup>[2]</sup>		x		group of commands that unselects a class of tags in the field; unselection criteria is the data at a specified address
GROUP_SELECT_yy_FLAGS <sup>[3]</sup>	x	x		group of commands that selects a class of tags in the field to participate in the identification process; selection criteria is the flag status of the IC
GROUP_UNSELECT_yy_FLAGS <sup>[3]</sup>		x		group of commands that unselects a class of tags in the field; unselection criteria is the flag status of the IC
MULTIPLE_UNSELECT		x		unselect tags from participating on the write_multiple process
FAIL		x		anticollision command after recognized collision
SUCCESS		x		anticollision command after recognized identification or no-response
RESEND		x		anticollision command after incorrect response
INITIALIZE	x	x	x	moves all tags in the READY state
READ	x	x	x	reads data of a defined tag from a special address
DATA_READ		x	x	reads data of a defined tag from a special address; typical after an identification process
READ_VERIFY	x	x	x	reads data of a defined tag from a special address; typical after a write process
WRITE	x	x	x	writes one byte to a special address of one tag
WRITE_MULTIPLE		x	x	writes one byte to a special address of all selected tags
WRITE4BYTE_MULTIPLE		x	x	writes four byte to a special address of all selected tags
WRITE4BYTE	x	x	x	writes four byte to a special address of one tag
LOCK			x	locks a special byte of one tag
QLOCK	x	x	x	queries the lock status of a special byte of one tag
READ_PORT	x	x	x	reads port data or defined tag port address
READ_VARIABLE	x	x	x	reads defined number of bytes from a certain memory address of a defined tag
READ_VERIFY	x	x	x	reads data of a defined tag from a special address; typical after a WRITE4BYTE command

[1] Commands active in state READY (R), ID (I) and DATA\_EXCHANGE (D) if marked with "x" and ignored otherwise.

[2] xx can be "EQ", "NE", "GT" or "LT".

[3] yy can be "EQ" or "NE".

For details on each command see [Section 11](#).

Table 5. State transition table

Initial state	Command name	Condition	Final state
READY	GROUP_SELECT_xx, GROUP_SELECT_yy_FLAGS	selection criteria does not match	READY
	GROUP_SELECT_xx, GROUP_SELECT_yy_FLAGS	selection criteria matches	ID
	INITIALIZE		READY
	READ, WRITE, WRITE4BYTE, QLOCK, READ_PORT, READ_VARIABLE	UID matches	DATA EXCHANGE
	READ, WRITE, WRITE4BYTE, QLOCK, READ_PORT, READ_VARIABLE	UID does not match	READY
	READ_VERIFY_4BYTE	UID matches and WRITE_OK [1]	DATA EXCHANGE
	READ_VERIFY_4BYTE	UID does not match or not WRITE_OK [1]	READY
ID	GROUP_SELECT_xx, GROUP_SELECT_yy_FLAGS		ID
	GROUP_UNSELECT_xx, GROUP_UNSELECT_yy_FLAGS	unselect criteria does not match	ID
	GROUP_UNSELECT_xx, GROUP_UNSELECT_yy_FLAGS	unselect criteria matches	READY
	MULTIPLE_UNSELECT	Data [2] incorrect or not WRITE_OK [1]	ID
	MULTIPLE_UNSELECT	Data [2] correct and WRITE_OK [1]	READY
	FAIL, SUCCESS, RESEND		ID
	INITIALIZE		READY
	READ, DATA_READ, WRITE, WRITE4BYTE, QLOCK, READ_PORT, READ_VARIABLE	UID matches	DATA EXCHANGE
	READ, DATA_READ, WRITE, WRITE4BYTE, QLOCK, READ_PORT, READ_VARIABLE	UID does not match	ID
	READ_VERIFY_4BYTE	UID does not match or not WRITE_OK [1]	ID
	READ_VERIFY_4BYTE	UID matches and WRITE_OK [1]	DATA EXCHANGE
	WRITE_MULTIPLE, WRITE4BYTE_MULTIPLE		ID
	DATA_EXCHANGE	INITIALIZE	
READ, DATA_READ, READ_VERIFY, READ_PORT, READ_VARIABLE			DATA EXCHANGE
WRITE, WRITE_MULTIPLE			DATA EXCHANGE
WRITE4BYTE, WRITE4BYTE_MULTIPLE			DATA EXCHANGE
LOCK, QLOCK			DATA EXCHANGE

[1] Flag that indicates a proper write process (see [Section 8.3.2 "WRITE\\_OK"](#)).

[2] Written data from a previous write command.

[3] Commands not listed at a certain initial state are ignored by a tag that is in this state.

### 8.3 Flags

The flag byte can be accessed by the GROUP\_SELECT\_yy\_FLAGS and GROUP\_UNSELECT\_yy\_FLAGS commands. In the BYTE\_MASK (see [Section 11.2.1.2](#)) of those commands a matching criteria can be set. As only the two least significant bit of the flag byte are used in this IC all others are zero (logic 0).

The SL3ICS30 supports a field of 8 flags. This field is called FLAGS.

**Table 6. Flags**

Bit	Name
FLAG1 (LSB)	DE_SB (Data_Exchange Status Bit)
FLAG2	WRITE_OK
FLAG3	0 (RFU)
FLAG4	0 (RFU)
FLAG5	0 (RFU)
FLAG6	0 (RFU)
FLAG7	0 (RFU)
FLAG8 (MSB)	0 (RFU)

#### 8.3.1 Data\_Exchange status bit

The tag sets this bit when the tag goes into the DATA\_EXCHANGE state and keeps it set unless it moves into the POWER-OFF state. When the DE\_SB is set and the tag comes into the POWER-OFF state, then the tag triggers a timer that will reset the DE\_SB bit after  $t_{DE\_SB}$ .

When the tag goes into the READY state after POWER-OFF state and the DE\_SB bit is still set, the timer is reset and DE\_SB stays set.

When the tag receives the INITIALIZE command, then it reset the DE\_SB bit immediately.

#### 8.3.2 WRITE\_OK

LSB+1 (Bit 1) of the flag byte. This bit indicates that a previous write operation was done without any problems. If WRITE\_OK is set, the last programming cycle of the EEPROM was done properly.

The WRITE\_OK bit is reset by any inadequate EEPROM write cycle or a voltage supply interruption (see [Section 9.7](#)). Further, it is reset latest at the begin of the second command following a write access to the EEPROM.

NOTE: To be absolute sure that the programming process was done correct, the data needs to be verified with an additional read command.

## 8.4 Lockable state machine

This state machine is used to control the possibility of locking bytes in the EEPROM.

The lockable state machine has 2 states, IDLE and LOCKABLE. Initially, the state is IDLE. After any valid READ, DATA\_READ, WRITE and QLOCK commands to the tag, the state becomes LOCKABLE, and locks on that dedicated byte are allowed. The specified address (starting address) is saved.

If a LOCK command to the same address of the same tag is received and the state is LOCKABLE, the lock proceeds.

If any other command is received, including a command to another tags, or any command packet has an error, the state returns to IDLE and the lock is no longer allowed.

See also [Section 10](#) and [Section 11](#).

## 8.5 Collision arbitration, anticollision

The interrogator may use the GROUP\_SELECT and GROUP\_UNSELECT commands to define all or a subset of tags in the field to participate in the collision arbitration. It then may use the identification commands to run the collision arbitration algorithm.

For the collision arbitration, the tag supports two pieces of hardware on the tag:

- an 8-bit counter: COUNT
- a random '1' or '0' generator

In the beginning, a group of tags is moved to the ID state by GROUP\_SELECT commands, and their internal counters are set to logic 0. Subsets of the group may be unselected by GROUP\_UNSELECT commands back to the READY state. Other groups can be selected before the identification process begins. Simulation results show no advantage in identifying one large group or a few smaller groups.

After above described selection, the following loop should be performed:

1. All tags in the ID state with the counter COUNT at '0' transmit their ID. This set initially includes all the selected tags.
2. If more than one tag transmits, the base station receives an erroneous response. The FAIL command shall be sent.
3. All tags receiving a FAIL command with COUNT not equal to logic 0 will increment COUNT. That is, they move further away from being able to transmit. All tags receiving FAIL, having a COUNT of '0' (those that just transmitted) will generate a random number. Those that roll a '1' will increment COUNT and will not transmit. Those that roll a zero will keep COUNT at zero and send their UID again. One of four possibilities now occurs:
4. If more than one tag transmits, the FAIL step 2 repeats. (Possibility 1)
5. If all tags roll a '1', none transmits. The interrogator receives nothing. It sends the SUCCESS command. All the counters decrement, and the tags with a count of '0' transmit. Typically, this returns to step 2. (Possibility 2)

6. If only one tag transmits and the ID is received correctly, the base station shall send the DATA\_READ command with the ID. If the DATA\_READ command is received correctly, then that tag moves to the DATA\_EXCHANGE state and will transmit its data. The base station shall send SUCCESS. All tags in the ID state decrement COUNT.
7. If only one tag has a count of '1' and transmits, step 5 or 6 repeats. If more than one tag transmits, step 2 repeats. (Possibility 3)
8. If only one tag transmits and the ID is received with an error, the base station shall send the RESEND command. If the ID is received correctly, step 5 repeats. If the ID is received again some variable number of times (this number can be set based on the level of error handling desired for the system), it is assumed that more than one tag is transmitting, and step 2 repeats. (Possibility 4)

## 8.6 Data exchange sequences

### 8.6.1 Forward link

Every command starts with a command header consisting of PREAMBLE\_DETECT, PREAMBLE and START DELIMITER. In this document, the appearance of these sequences is given in NRZ format. A NRZ '1' means maximum field strength and NRZ '0' means lower or even zero field (see also [Section 9.3](#)). Compared to the Manchester coded data, these sequences are given in halfbits.

All other transmitted data will be defined Manchester coded. This means that the digital data will be defined by a falling or rising transition in the middle of the bit. Furthermore, this means that a Manchester coded bit can be defined by two halfbits of a NRZ code.

The forward link consists of the following sequences:

- PREAMBLE\_DETECT  
no transition allowed during this time
- PREAMBLE  
tag calibrates onto forward data rate
- START DELIMITER (STDEL)  
tag verifies its calibration
- COMMAND (CMD)
- Address + Byte Mask + Data  
only if required by the command
- CRC - 16  
16 check bits, calculated from COMMAND + Address + Byte Mask + Data
- WAIT  
only if COMMAND was a WRITE, to power the tag during EEPROM write

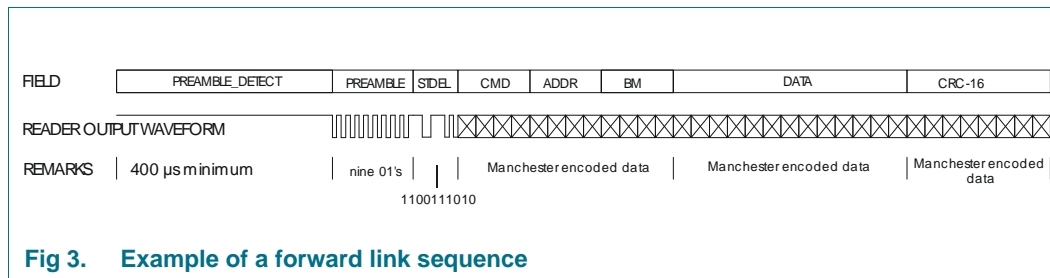

Fig 3. Example of a forward link sequence

### 8.6.1.1 Preamble

Table 7. Definition of forward PREAMBLE

	NRZ coded data stream
PREAMBLE	00 00 01 01 01 01 01 01 01 01 00 01 10 11 00 01

### 8.6.1.2 START DELIMITER

IC supports two Start Delimiters. See also [Section 9.2.1 “Communication rate”](#).

Table 8. Definition of START DELIMITER

Type	NRZ coded data stream
STDEL1 (x1 return rate)	11 00 11 10 10
STDEL2 (x4 return rate)	11 01 11 00 10 1

### 8.6.2 Return link

A return link header consists of QUIET and RETURN\_PREAMBLE. Just like the forward link header, this will be defined via NRZ coding. Here a NRZ ‘1’ means that the IC shortens the input pins. A NRZ ‘0’ does not affect the chip input impedance (see also [Section 9.3](#)).

Return data will be encoded in FM0. This means that on every edge of a bit a transition will occur. The digital data will be encoded by adding or non adding a transition in the middle of the bit. One FM0 bit is defined by 2 NRZ halfbits.

The return link consists of the following sequences, and starts immediately after the end of the forward link:

- QUIET
  - no transition allowed during this time
- RETURN PREAMBLE
  - interrogator may calibrate onto return data rate
- DATA
  - return data
- CRC - 16
  - 16 check bits, calculated from DATA

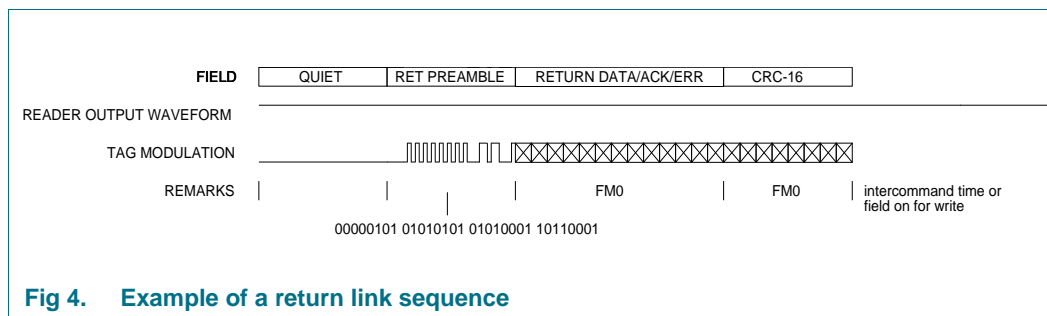

Fig 4. Example of a return link sequence

### 8.6.2.1 RETURN PREAMBLE

Table 9. Definition of forward RETURN PREAMBLE

	NRZ coded data stream
RETURN PREAMBLE	00 00 01 01 01 01 01 01 01 01 00 01 10 11 00 01

## 8.7 Bit and byte ordering

In all byte fields, the most significant bit (MSB) is transmitted first, proceeding to the least significant bit (LSB).

In all WORD\_DATA (8 byte) or 4 BYTE\_DATA (4 byte) data fields, the most significant byte is transmitted first. The most significant byte is the byte at the specified address. The least significant byte is the byte at the specified address plus 7 or plus 3. That is, bytes are transmitted in incrementing address order.

The byte significance is relevant to data transmission and the GROUP\_SELECT and GROUP\_UNSELECT greater than (“GT”) and less than (“LT”) comparisons.

The MSB of the byte mask corresponds to the most significant data byte, the byte at the specified address.

The byte mask for WRITE4BYTES and WRITE4BYTES\_MULTIPLE uses only 4 bits. The MSB corresponds to the most significant byte that should be written. The 4 unused LSB’s in the byte mask are ignored.

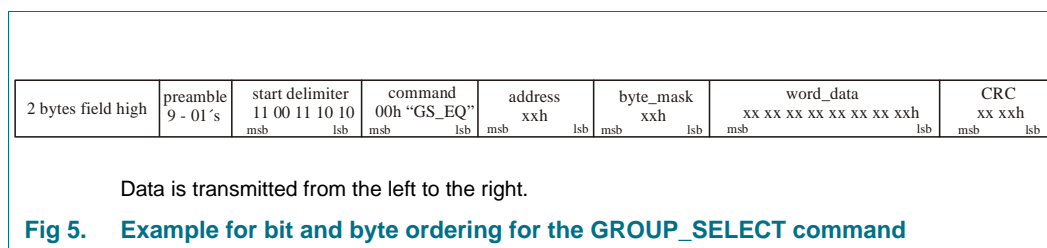

Fig 5. Example for bit and byte ordering for the GROUP\_SELECT command

## 8.8 Data integrity

There are two types of transmission errors: modulation coding errors (detectable per bit) and CRC errors (detectable per command). Both errors cause any command to be aborted. The tag does not respond. For all CRC errors, the tag returns to the READY state. For all coding errors, the tag returns to the READY state if a valid start delimiter had been detected. Otherwise, it maintains in its current state.

## 8.9 CRC definition

The CRC-16 is calculated according the CRC-CCITT standard polynomial  $X^{16}+X^{12}+X^5+1$ . The Cyclic Redundancy Check (CRC) is calculated on all data contained in a message, from the start of the command through to the end of data. This CRC is used from interrogator to tag and from tag to interrogator.

On receiving a command from the interrogator, the tag verifies if the checksum or the CRC value is valid. If it is invalid, it discards the frame and does neither respond, nor take any other action.

**Table 10. CRC definition**

CRC type	Length	Polynomial	Direction	Preset	Residue
CRC-CCITT	16 bits	$X^{16} + X^{12} + X^5 + 1$	forward and return link	'FFFF'	'0'

### 8.9.1 CRC algorithm

For computing the CRC:

- initialize the CRC accumulator to all ones - FFFFh
- accumulate data using the polynomial  $X^{16} + X^{12} + X^5 + 1$
- invert the resulting CRC value
- attach the inverted CRC-16 to the end of the packet and transmit it MSB first

For checking the CRC:

- compute the CRC on the incoming packet
- accumulate the inverted CRC in the CRC registers
- verify that the accumulator is all zeroes

An example for the CRC calculation is given in the following section.

### 8.9.2 CRC calculation example

This example refers to a SUCCESS command.

SUCCESS command code: '09 hex or 00001001b'.

The packet sent from the interrogator to the tag consists of the following blocks, but only the SUCCESS command (09h), is used in the CRC calculation.

PREAMBLE_ DETECT	PREAMBLE	START DELIMITER	SUCCESS command - 09h	CRC-16

The CRC is calculated on the SUCCESS command as the field is transmitted MSB first.

The following example shows the values of the 16 CRC registers as the data is shifted through the CRC registers.



**Table 11. Practical example of CRC calculation for a 'SUCCESS' command in the Interrogator**

Step	Input (SUCCESS Cmd)	Calculated CRC in interrogator
1	0	'EFD F'
2	0	'CF9 F'
3	0	'8F1 F'
4	0	'0E1 F'
5	1	'0C1 F'
6	0	'183 E'
7	0	'307 C'
8	1	'70D 9'

**Table 12. Practical example of CRC checking for a 'SUCCESS' command in the Tag**

Step	Input (Sent CRC-16)	Calculated CRC in interrogator
0		'70D 9'
1	0	'E1B 2'
2	1	'C36 4'
3	1	'86C 8'
4	1	'0D9 0'
5	0	'1B2 0'
6	0	'364 0'
7	0	'6C8 0'
8	0	'D90 0'
9	1	'B20 0'
10	1	'640 0'
11	0	'C80 0'
12	1	'900 0'
13	1	'200 0'
14	0	'400 0'
15	0	'800 0'
16	1	'000 0'

## 9. Communication timing and waveforms

### 9.1 Forward link

The tag front end effectively filters out short power interruption. Longer power interruptions will be detected and are interpreted as communication, tag writing, or, if exceeding a certain criteria in duration, may generate a tag reset (see [Section 9.7](#)).

If tag power is to be maintained between commands, the interrogator field must be kept on. If power is interrupted within  $t_{SD}$  (as if might happen during interrogator frequency hops from one channel to another), the tag may interpret the hop event as the beginning of the PREAMBLE field. The tag will not succeed to decode the first command that follows the hop. If a data stream with 10 closely-spaced rising edges (i.e. 10 Manchester 0's) is sent to the tag immediately after a known brief power interruption event, however, the first command following the event will be decoded (that command must start with the PREAMBLE\_DETECT field). The sequence that provides the ten rising edges to the tag is called TAG RESYNC.

**Table 13. Definition of TAG RESYNC**

	NRZ coded data stream
TAG RESYNC	01 01 01 01 01 01 01 01 01 01

In order for a write to be successful, tag power must be maintained throughout the  $t_{EEwrite}$  execution time. Furthermore, the on-chip supply voltage required for a successful write is higher than that required for a successful read (this asymmetry causes the asymmetry between tag read and write ranges). Power interruptions during the write cycle may be unavoidable, however, resulting in corrupted or unreliable data. The commands READ\_VERIFY, MULTIPLE\_UNSELECT, GROUP\_SELECT\_FLAGS, and GROUP\_UNSELECT\_FLAGS are used to identify bad data immediately after the WRITE, WRITE4BYTE, WRITE\_MULTIPLE, WRITE4BYTE\_MULTIPLE or LOCK process so that it can be rewritten. Please see [Section 11](#). for details regarding those commands.

#### 9.1.1 Communication rate

As the chip supports two different values of modulation index (see [Table 15](#)) in the forward link, there are also different limits for the communication rate.

**Table 14. Forward data rate**

Modulation index		Forward data rate
Type 18% <a href="#">[1]</a>	18%	8 to 40 kBits/s
Type 100% <a href="#">[2]</a>	100%	30 to 40 kBits/s

[1] Type 18 % is intended to be used to fit into CEPT/ETSI and FCC regulations (for details see [Section 16](#) "References").

[2] Type 100% is intended to be used for FCC regulations only (for details see [Section 16](#) "References").

### 9.1.2 Modulation Waveform of Interrogator Modulation

The rectifier and demodulator of the IC is built in such a way that a command is recognized when transmitted as defined in [Figure 6](#) and [Table 15](#).

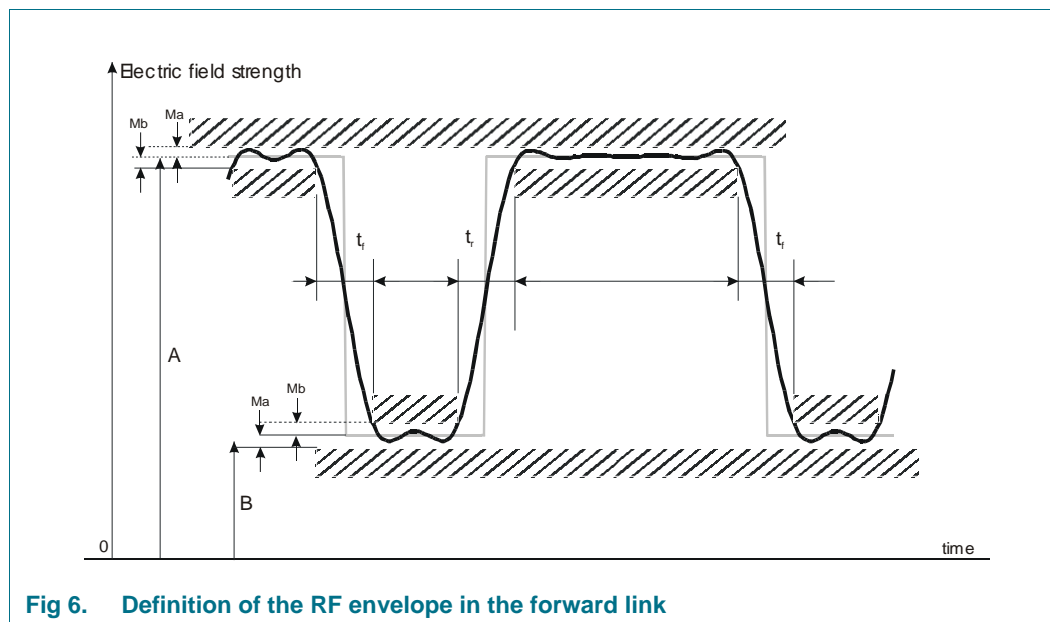

“A” in [Figure 6](#) is the maximum amplitude of the RF field envelope. “B” is always smaller than “A”

$$\text{modulation index (m)} = \frac{A - B}{A + B} \quad (1)$$

The IC supports two values of modulation index: 18% and 100% as typical values.

**Table 15. Modulation Type 18 % - Parameters for the RF envelop shape**

Parameter	Min	Typ	Max	Unit
m	15	18	20	%
Ma = Mb	0	-	0.05 × (A-B)	-
tr,10-90% (A-B)	0	-	0.17 × T <sub>bitrate</sub>	s
tf,90-10% (A-B)	0	-	0.17 × T <sub>bitrate</sub>	s

[1] T<sub>bitrate</sub> is the bit period of the forward link bitrate.

[2] All values are valid for matched RF operation only.

**Table 16. Modulation Type 100% - Parameters for the RF envelop shape**

Parameter	Min	Typ	Max	Unit
m	90	100	100	%
Ma = Mb	0	-	0.03 × (A-B)	-
tr,10-90% (A-B)	0	-	0.1 × T <sub>bitrate</sub>	s
tf,90-10% (A-B)	0	-	0.1 × T <sub>bitrate</sub>	s

[1] T<sub>bitrate</sub> is the bit period of the forward link bitrate.

Table 17. Bit duty cycle tolerance

	Min	Typ	Max	Unit
forward duty cycle	45	50	55	%

### 9.1.3 RF envelope of data streams

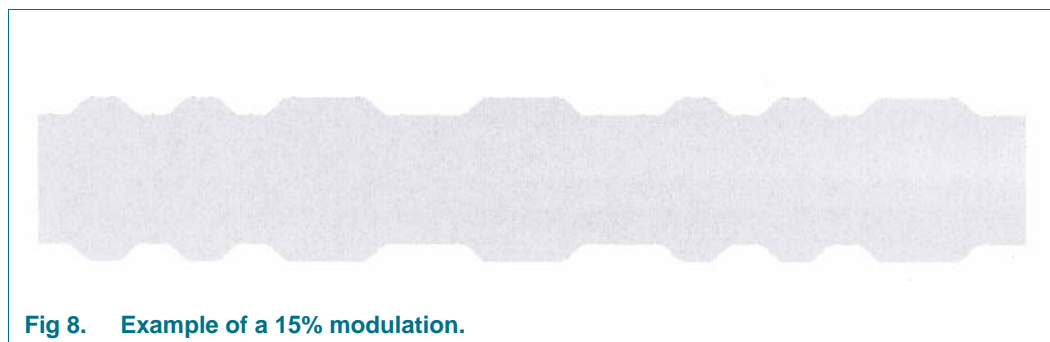
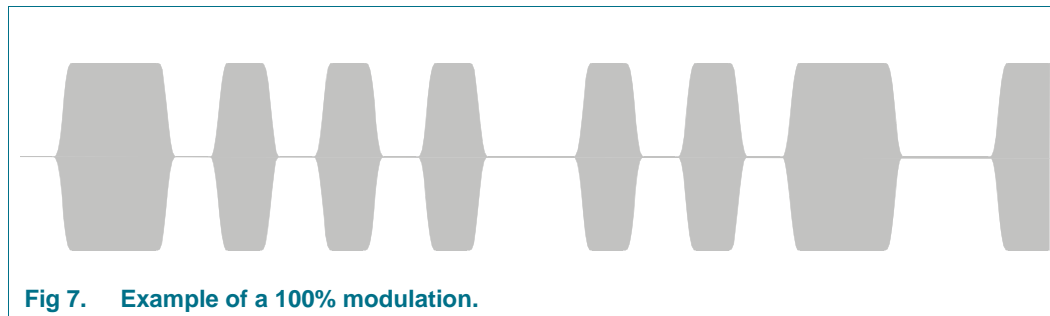

## 9.2 Return link

### 9.2.1 Communication rate

The chip supports two different kinds of return link data rates. The START DELIMITER (see [Section 8.6.1.2.](#)) of the command generating the response defines the data rate for the return link.

Table 18. Return data rate

Start delimiter	Return data rate	Tolerance
11 00 11 10 10	1 x forward data rate	± 15%
11 01 11 00 10 1	4 x forward data rate	± 15%

### 9.2.2 Modulation Waveform of Transponder Modulation

A modulation transistor operating right behind the rectifier is used to minimize the tag antenna impedance (ideally a short between the IC input pins) during back modulation.

Table 19. Bit duty cycle tolerance

	Min	Typ	Max	Unit
return bit duty cycle	40	50	60	%

## 9.3 Bit Coding

### 9.3.1 Forward Link

Maximum RF field is a NRZ '1' ("A" in [Figure 6](#)), modulated RF field level equals NRZ '0' ("B" in [Figure 6](#)).

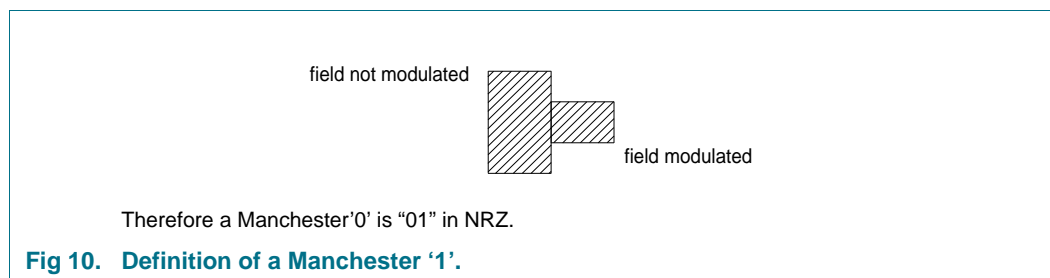
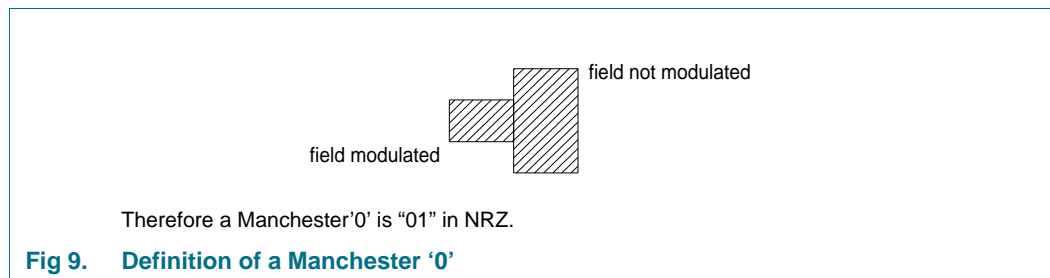

### 9.3.2 Return Link

NRZ '0' is no modulation, that means a high chip input impedance.

NRZ '1' is a modulation (modulation transistor turned on), that means a very low chip input impedance.

Within the FM0 encoded data patterns, a logical '0' is transmitted, if there is transition at the midbit. A logical '1' is transmitted if no transition occurs at the midbit. Note: in FM0 encoding a transition occurs additionally at all bit boundaries.

## 9.4 Response Time

The tag immediately starts sending back the return sequence after a correct command was received. As this sequence starts with a QUIET field (see [Section 8.6.2](#)) the interrogator may use the time for that field for settling its receiver section.

**Table 20. Maximum interrogator settling time**

QUIET field length	$16 \times T_{\text{return bit rate}} - 0.75 \times T_{\text{forward bit rate}}$
--------------------	--

## 9.5 Regeneration Time

After a response of the tag or the end of a WAIT field, the tag is immediately able to receive a new command sequence from the interrogator. This sequence will again start with a PREAMBLE DETECT field.

## 9.6 Start-up Time

In general no special rise time is required. However, before starting data transmission to the tag, the interrogator has to establish a permanent carrier. If one uses the begin of ramp up of the field as starting time of a new command (as may be desired after a frequency hop, to shorten the communication time) the values defined in [Figure 11](#) and [Table 21](#) hold.

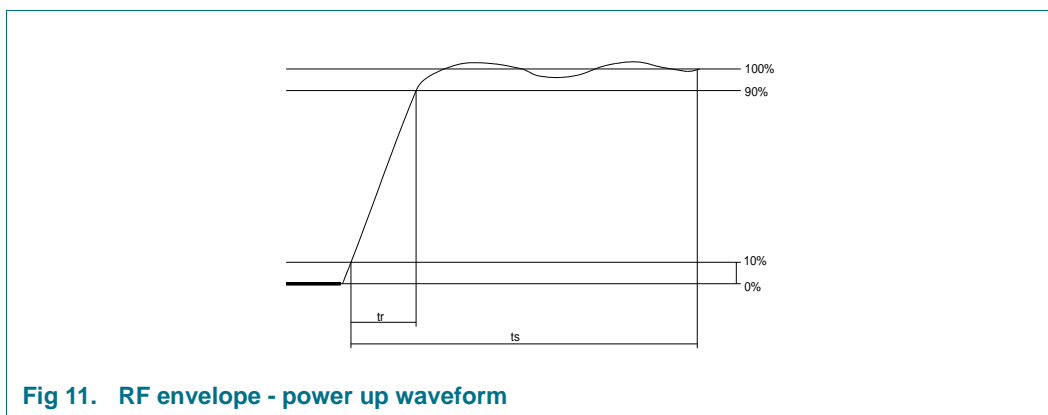

**Table 21. Timing limits**

Symbol	Min	Typ	Max	Unit
$t_r$	0		30	$\mu\text{s}$
$t_s$	400			$\mu\text{s}$

Note: Respecting above values, the power up process can be used for the PREAMBLE\_DETECT field. If the power interruption for the tag was in the range of  $t_{NN} < t \leq t_{SD}$ , a TAG RESYNC has to be used before the next command (see [Section 9.7](#)).

## 9.7 Power interruptions

Power interruptions of different times will lead to the following consequences:

**Table 22. Tag reaction on power interruptions**

Power interruption time: $T_{\text{interrupt}}$		Consequences
FROM	TO	
0	$t_{NN}$	No notice of interruption by the tag
$t_{NN}$	$t_{SD}$	Start of demodulation by the tag due to the interrupt may happen, if the tag is not reset due to power shortage.
$t_{SD}$	$t_{DE\_SB}$	Date exchange status bit stays valid, despite that the digital state information is lost.
$t_{DE\_SB}$		Tag loses all internal state information and the data exchange status bit is reset.

## 10. Memory

- Tag memory size:
  - 2048 bits
- ID memory size:
  - 8 bytes
- User memory size:
  - 216 bytes

All transmitted ADDRESS fields in the forward link has to be within the range of 0 to 223 ('0h' to 'DFh'), as this address refers to byte units. If an ADDRESS field is received that exceeds 'DFh', the command is ignored.

Each byte has an associated lock bit. If this lock bit is set to '1' the data of the byte cannot be changed anymore. This means that no more write commands can be processed on that byte.

Note: In case a read command uses a valid value for ADDRESS, but the number of bytes read by the command exceed 'DFh' is not defined.

### 10.1 Memory organization

The memory is organized byte-wise. Each byte has a dedicated lock bit.

Writing with the commands WRITE4BYTE and WRITE4BYTE\_MULTIPLE is only possible on a 4 byte boundary: 0, 4, 8, ...

### 10.2 Definition of block contents

#### 10.2.1 UID

The Unique ID (UID) is a 64 bit number, and is located in the bytes from 0 to 7. The most significant byte is stored on byte location 0. The bytes associated with the UID have to be locked latest after final label test.

### 10.3 Configuration of delivered ICs

**Table 23. Configuration of delivered ICs**

Memory Address	Memory Content	Lock Status	Comment
Byte 0, 1	E0, 04 hex	locked	unique serial number
Byte 2 - 7	xx hex	locked	unique serial number
Byte 8 - 10	00 hex	unlocked	user memory
Byte 11	02 hex	unlocked	user memory
Byte 12 - 17	FF hex	unlocked	user memory
Byte 18 - 219	00 hex	unlocked	user memory
Byte 220 - 223	57 5F 4F 4B hex	unlocked	"w_ok" in ASCII, user memory

## 11. Commands

### 11.1 Definitions

Table 24. Command codes and format

Command name	Code	Parameters			
GROUP_SELECT_EQ	00h	ADDRESS	BYTE_MASK	WORD_DATA	
GROUP_SELECT_NE	01h	ADDRESS	BYTE_MASK	WORD_DATA	
GROUP_SELECT_GT	02h	ADDRESS	BYTE_MASK	WORD_DATA	
GROUP_SELECT_LT	03h	ADDRESS	BYTE_MASK	WORD_DATA	
GROUP_UNSELECT_EQ	04h	ADDRESS	BYTE_MASK	WORD_DATA	
GROUP_UNSELECT_NE	05h	ADDRESS	BYTE_MASK	WORD_DATA	
GROUP_UNSELECT_GT	06h	ADDRESS	BYTE_MASK	WORD_DATA	
GROUP_UNSELECT_LT	07h	ADDRESS	BYTE_MASK	WORD_DATA	
FAIL	08h	none			
SUCCESS	09h	none			
INITIALIZE	0Ah	none			
DATA_READ	0Bh	ID	ADDRESS		
READ	0Ch	ID	ADDRESS		
WRITE	0Dh	ID	ADDRESS	BYTE_DATA	
WRITE_MULTIPLE	0Eh	ADDRESS	BYTE_DATA		
LOCK	0Fh	ID	ADDRESS		
QUERY_LOCK	11h	ID	ADDRESS		
READ_VERIFY	12h	ID	ADDRESS		
MULTIPLE_UNSELECT	13h	ADDRESS	BYTE_DATA		
RESEND	15h	none			
CALIBRATE	16h	none			
GROUP_SELECT_EQ_FLAGS	17h	BYTE_MASK	BYTE_DATA		
GROUP_SELECT_NE_FLAGS	18h	BYTE_MASK	BYTE_DATA		
GROUP_UNSELECT_EQ_FLAGS	19h	BYTE_MASK	BYTE_DATA		
GROUP_UNSELECT_NE_FLAGS	1Ah	BYTE_MASK	BYTE_DATA		
WRITE4BYTE	1Bh	ID	ADDRESS	BYTE_MASK	4BYTE_DATA
WRITE4BYTE_MULTIPLE	1Ch	ADDRESS	BYTE_MASK	4BYTE_DATA	
READ_VERIFY_4BYTE	1Dh	ID	ADDRESS		
READ_VARIABLE	51h	ID	ADDRESS	LENGTH	
READ_PORT	52h	ID	ADDRESS		



**Table 25. Command fields**

Field name	Field size
COMMAND	1 byte
ADDRESS	1 byte
BYTE_MASK	1 byte
ID	8 bytes
WORD_DATA	8 bytes
BYTE_DATA	1 byte
4BYTE_DATA	4 bytes
LENGTH	1 byte

**Table 26. Tag response**

Response name	Response size	Value
ACKNOWLEDGE	1 byte	00
ACKNOWLEDGE_NOK	1 byte	00
ACKNOWLEDGE_OK	1 byte	01
ERROR_NOK	1 byte	FE
ERROR	1 byte	FF
ERROR_OK	1 byte	FF
ID	8 bytes	n/a
WORD_DATA	8 bytes	n/a
BYTE_DATA	1 byte	n/a
CRC	2 bytes	n/a
VARIABLE_DATA	LENGTH bytes	n/a

## 11.2 Selection commands

Selection commands define a subset of tags in the field to be identified or written to and may be used as part of the collision arbitration.

### 11.2.1 Data comparison for selection commands

#### 11.2.1.1 Data comparison for selection commands on memory

Each select command of the commands

GROUP\_SELECT\_EQ, GROUP\_SELECT\_NE, GROUP\_SELECT\_GT,  
GROUP\_SELECT\_LT, GROUP\_UNSELECT\_EQ, GROUP\_UNSELECT\_NE,  
GROUP\_UNSELECT\_GT, GROUP\_UNSELECT\_LT

has three arguments (parameter and data):

- ADDRESS
- BYTE\_MASK
- WORD\_DATA

and the tag shall do one of four possible comparisons:

- EQ: M equal D
- NE: M not equal D
- GT: M greater than D
- LT: M lower than D

The argument of the comparison are:

M7 MSB	M6	M5	M4	M3	M2	M1	M0 LSB
Tag memory content at ADDRESS+0	Tag memory content at ADDRESS+1	Tag memory content at ADDRESS+2	Tag memory content at ADDRESS+3	Tag memory content at ADDRESS+4	Tag memory content at ADDRESS+5	Tag memory content at ADDRESS+6	Tag memory content at ADDRESS+7

$$[1] \quad M = M0 + M1 * 2^8 + M2 * 2^{16} + M3 * 2^{24} + M4 * 2^{32} + M5 * 2^{40} + M6 * 2^{48} + M7 * 2^{56}$$

and the argument of the command:

D7 MSB	D6	D5	D4	D3	D2	D1	D0 LSB
First byte after command							Last byte after command

$$[1] \quad D = D0 + D1 * 2^8 + D2 * 2^{16} + D3 * 2^{24} + D4 * 2^{32} + D5 * 2^{40} + D6 * 2^{48} + D7 * 2^{56}$$

The argument **BYTE\_MASK** defines what bytes to be considered for comparison:

<b>BYTE_MASK</b>	<b>WORD_DATA</b>
Bit 7 (MSB) is set	Consider D7 and M7 for comparison
Bit 6 is set	Consider D6 and M6 for comparison
Bit 5 is set	Consider D5 and M5 for comparison
Bit 4 is set	Consider D4 and M4 for comparison
Bit 3 is set	Consider D3 and M3 for comparison
Bit 2 is set	Consider D2 and M2 for comparison
Bit 1 is set	Consider D1 and M1 for comparison
Bit 0 (MSB) is set	Consider D0 and M0 for comparison
Bit 7 (MSB) is cleared	Ignore D7 and M7 for comparison
Bit 6 is cleared	Ignore D6 and M6 for comparison
Bit 5 is cleared	Ignore D5 and M5 for comparison
Bit 4 is cleared	Ignore D4 and M4 for comparison
Bit 3 is cleared	Ignore D3 and M3 for comparison
Bit 2 is cleared	Ignore D2 and M2 for comparison
Bit 1 is cleared	Ignore D1 and M1 for comparison
Bit 0 (LSB) is cleared	Ignore D0 and M0 for comparison

#### 11.2.1.2 Data comparison for selection commands on flags

Each select command of the commands

GROUP\_SELECT\_EQ\_FLAGS

GROUP\_SELECT\_NE\_FLAGS,

GROUP\_UNSELECT\_EQ\_FLAGS\_EQ,

GROUP\_UNSELECT\_NE\_FLAGS, has 2 arguments (parameter and data):

- BYTE\_MASK
- BYTE\_DATA

and the tag shall do one of 2 possible comparisons:

- EQ: FLAGS equal D
- NE: FLAGS not equal D

The arguments of the comparison are FLAGS, as defined in [Section 8.3 “Flags”](#) and the argument of the command D, consisting of the bits D7 (MSB) to D0 (LSB).

The argument **BYTE\_MASK** defines what bytes to be considered for comparison:

BYTE_MASK	WORD_DATA
Bit 7 (MSB) is set	Consider D7 and FLAG7 for comparison
Bit 6 is set	Consider D6 and FLAG6 for comparison
Bit 5 is set	Consider D5 and FLAG5 for comparison
Bit 4 is set	Consider D4 and FLAG4 for comparison
Bit 3 is set	Consider D3 and FLAG3 for comparison
Bit 2 is set	Consider D2 and FLAG2 for comparison
Bit 1 is set	Consider D1 and FLAG1 for comparison
Bit 0 (MSB) is set	Consider D0 and FLAG0 for comparison
Bit 7 (MSB) is cleared	Ignore D7 and FLAG7 for comparison
Bit 6 is cleared	Ignore D6 and FLAG6 for comparison
Bit 5 is cleared	Ignore D5 and FLAG5 for comparison
Bit 4 is cleared	Ignore D4 and FLAG4 for comparison
Bit 3 is cleared	Ignore D3 and FLAG3 for comparison
Bit 2 is cleared	Ignore D2 and FLAG2 for comparison
Bit 1 is cleared	Ignore D1 and FLAG1 for comparison
Bit 0 (LSB) is cleared	Ignore D0 and FLAG0 for comparison

**Formula describing in the EQUAL function:**

The EQUAL comparison passes, if

$$(!B7 + (D7 = FLAG7)) \cdot (!B6 + (D6 = FLAG6)) \cdot (!B5 + (D5 = FLAG5)) \cdot (!B4 + (D4 = FLAG4)) \\ \cdot (!B3 + (D3 = FLAG3)) \cdot (!B2 + (D2 = FLAG2)) \cdot (!B1 + (D1 = FLAG1)) \cdot (!B0 + (D0 = FLAG0))$$

is true.

**Formula describing in the UNEQUAL function:**

The UNEQUAL comparison passes, if

$$B7 \cdot (D7! = FLAG7) + B6 \cdot (D6! = FLAG6) + B5 \cdot (D5! = FLAG5) + B4 \cdot (D4! = FLAG4) \\ + B3 \cdot (D3! = FLAG3) + B2 \cdot (D2! = FLAG2) + B1 \cdot (D1! = FLAG1) + B0 \cdot (D0! = FLAG0)$$

is true.

### 11.2.2 GROUP\_SELECT\_EQ

When receiving a GROUP\_SELECT\_EQ command, a tag which is in the READY state reads the 8-byte memory content beginning at the specified ADDRESS and compares it with the WORD\_DATA sent by the interrogator. In case the memory content is equal to WORD\_DATA the tag sets its internal counter COUNT to logic 0, reads its UID, sends back the UID and goes into the state ID.

When receiving a GROUP\_SELECT\_EQ command, a tag which is in the ID state sets its internal counter COUNT to logic 0, reads its UID, sends back the UID and stays in the ID state.

In all other cases the tag will not send any reply.

#### Command sequence

Preamble	Start Delimiter	Command	ADDRESS	BYTE_MASK	WORD_DATA	CRC
----------	-----------------	---------	---------	-----------	-----------	-----

#### Response sequence in case the tag is in the ID state or meeting selection criteria

Return Preamble	ID	CRC
-----------------	----	-----

[1] If the byte mask is zero, GROUP\_SELECT\_EQ selects all tags.

### 11.2.3 GROUP\_SELECT\_NE

When receiving a GROUP\_SELECT\_NE command, a tag which is in the READY state reads the 8-byte memory content beginning at the specified ADDRESS and compares it with the WORD\_DATA sent by the interrogator. In case the memory content is not equal to WORD\_DATA the tag sets its internal counter COUNT to logic 0, reads its UID, sends back the UID and goes into the state ID.

When receiving a GROUP\_SELECT\_NE command, a tag which is in the ID state sets its internal counter COUNT to logic 0, reads its UID, sends back the UID and stays in the ID state.

In all other cases the tag will not send any reply.

#### Command sequence

Preamble	Start Delimiter	Command	ADDRESS	BYTE_MASK	WORD_DATA	CRC
----------	-----------------	---------	---------	-----------	-----------	-----

#### Response sequence in case the tag is in the ID state or meeting selection criteria

Return Preamble	ID	CRC
-----------------	----	-----

### 11.2.4 GROUP\_SELECT\_GT

When receiving a GROUP\_SELECT\_GT command, a tag which is in the READY state reads the 8-byte memory content beginning at the specified ADDRESS and compares it with the WORD\_DATA sent by the interrogator. In case the memory content is greater than WORD\_DATA the tag sets its internal counter COUNT to logic 0, reads its UID, sends back the UID and goes into the state ID.

When receiving a GROUP\_SELECT\_GT command, a tag which is in the ID state sets its internal counter COUNT to logic 0, reads its UID, sends back the UID and stays in the ID state.

In all other cases the tag will not send any reply.

#### Command sequence

Preamble	Start Delimiter	Command	ADDRESS	BYTE_MASK	WORD_DATA	CRC
----------	-----------------	---------	---------	-----------	-----------	-----

#### Response sequence in case the tag is in the ID state or meeting selection criteria

Return Preamble	ID	CRC
-----------------	----	-----

### 11.2.5 GROUP\_SELECT\_LT

When receiving a GROUP\_SELECT\_LT command, a tag which is in the READY state reads the 8-byte memory content beginning at the specified ADDRESS and compares it with the WORD\_DATA sent by the interrogator. In case the memory content is lower than WORD\_DATA the tag sets its internal counter COUNT to logic 0, reads its UID, sends back the UID and goes into the state ID.

When receiving a GROUP\_SELECT\_LT command, a tag which is in the ID state sets its internal counter COUNT to logic 0, reads its UID, sends back the UID and stays in the ID state.

In all other cases the tag will not send any reply.

#### Command sequence

Preamble	Start Delimiter	Command	ADDRESS	BYTE_MASK	WORD_DATA	CRC
----------	-----------------	---------	---------	-----------	-----------	-----

#### Response sequence in case the tag is in the ID state or meeting selection criteria

Return Preamble	ID	CRC
-----------------	----	-----

### 11.2.6 GROUP\_UNSELECT\_EQ

When receiving a GROUP\_UNSELECT\_EQ command, a tag which is in the ID state reads the 8-byte memory content beginning at the specified ADDRESS and compares it with the WORD\_DATA sent by the interrogator. In case the memory content is equal to WORD\_DATA the tag goes into the READY state and will not send any reply. In case the comparison fails, the tag sets its internal counter COUNT to logic 0, reads its UID, sends back the UID and stays in the ID state.

#### Command sequence

Preamble	Start Delimiter	Command	ADDRESS	BYTE_MASK	WORD_DATA	CRC
----------	-----------------	---------	---------	-----------	-----------	-----

#### Response sequence in case of non meeting unselection criteria

Return Preamble	ID	CRC
-----------------	----	-----

### 11.2.7 GROUP\_UNSELECT\_NE

When receiving a GROUP\_UNSELECT\_NE command, a tag which is in the ID state reads the 8-byte memory content beginning at the specified ADDRESS and compares it with the WORD\_DATA sent by the interrogator. In case the memory content is not equal to WORD\_DATA the tag goes into the READY state and will not send any reply. In case the comparison fails, the tag sets its internal counter COUNT to logic 0, reads its UID, sends back the UID and stays in the ID state.

#### Command sequence

Preamble	Start Delimiter	Command	ADDRESS	BYTE_MASK	WORD_DATA	CRC
----------	-----------------	---------	---------	-----------	-----------	-----

#### Response sequence in case of non meeting unselection criteria

Return Preamble	ID	CRC
-----------------	----	-----

### 11.2.8 GROUP\_UNSELECT\_GT

When receiving a GROUP\_UNSELECT\_GT command, a tag which is in the ID state reads the 8-byte memory content beginning at the specified ADDRESS and compares it with the WORD\_DATA sent by the interrogator. In case the memory content is greater than WORD\_DATA the tag goes into the READY state and will not send any reply. In case the comparison fails, the tag sets its internal counter COUNT to logic 0, reads its UID, sends back the UID and stays in the ID state.

#### Command sequence

Preamble	Start Delimiter	Command	ADDRESS	BYTE_MASK	WORD_DATA	CRC
----------	-----------------	---------	---------	-----------	-----------	-----

#### Response sequence in case of non meeting unselection criteria

Return Preamble	ID	CRC
-----------------	----	-----

### 11.2.9 GROUP\_UNSELECT\_LT

When receiving a GROUP\_UNSELECT\_LT command, a tag which is in the ID state reads the 8-byte memory content beginning at the specified ADDRESS and compares it with the WORD\_DATA sent by the interrogator. In case the memory content is lower than WORD\_DATA the tag goes into the READY state and will not send any reply. In case the comparison fails, the tag sets its internal counter COUNT to logic 0, reads its UID, sends back the UID and stays in the ID state.

#### Command sequence

Preamble	Start Delimiter	Command	ADDRESS	BYTE_MASK	WORD_DATA	CRC
----------	-----------------	---------	---------	-----------	-----------	-----

#### Response sequence in case of non meeting unselection criteria

Return Preamble	ID	CRC
-----------------	----	-----

### 11.2.10 MULTIPLE\_UNSELECT

When receiving a MULTIPLE\_UNSELECT command, a tag which is in the ID state reads the 1-byte memory content beginning at the specified ADDRESS and compares it with the BYTE\_DATA sent by the interrogator. In case the memory content is equal to BYTE\_DATA and the flag WRITE\_OK is set, then the tag goes into the state READY and will not send any reply. In case the comparison fails, the tag sets its internal counter COUNT to logic 0, reads its UID and sends back the UID.

#### Command sequence

Preamble	Start Delimiter	Command	ADDRESS	BYTE_MASK	WORD_DATA	CRC
----------	-----------------	---------	---------	-----------	-----------	-----

#### Response sequence in case of non meeting unselection criteria

Return Preamble	ID	CRC
-----------------	----	-----

This command may be used to unselect all tags that had a successful write, while tags that had a weak write or write problems stay selected.



### 11.2.11 GROUP\_SELECT\_EQ\_FLAGS

When receiving a GROUP\_SELECT\_EQ\_FLAGS command, a tag which is in the READY state compares the FLAGS with the BYTE\_DATA sent by the interrogator. In case the FLAGS are equal to BYTE\_DATA the tag sets its internal counter COUNT to logic 0, reads its UID, sends back the UID and goes into the state ID.

When receiving a GROUP\_SELECT\_EQ\_FLAGS command, a tag which is in the ID state sets its internal counter COUNT to logic 0, reads its UID, sends back the UID and stays in the ID state.

In all other cases the tag will not send any reply.

#### Command sequence

Preamble	Start Delimiter	Command	ADDRESS	BYTE_MASK	WORD_DATA	CRC
----------	-----------------	---------	---------	-----------	-----------	-----

#### Response sequence in case the tag is in the ID state or meeting selection criteria

Return Preamble	ID	CRC
-----------------	----	-----

[1] If the byte mask is zero, GROUP\_SELECT\_EQ\_FLAGS selects all tags.

### 11.2.12 GROUP\_SELECT\_NE\_FLAGS

When receiving a GROUP\_SELECT\_NE\_FLAGS command, a tag which is in the READY state compares the FLAGS with the BYTE\_DATA sent by the interrogator. In case the FLAGS are not equal to BYTE\_DATA the tag sets its internal counter COUNT to 0, reads its UID, sends back its UID and goes into the state ID.

When receiving a GROUP\_SELECT\_NE\_FLAGS command a tag which is in the ID state sets its internal counter COUNT to logic 0, reads its UID, sends back the UID and goes in the ID state.

In all other cases the tag will not send a reply.

#### Command sequence

Preamble	Start Delimiter	Command	ADDRESS	BYTE_MASK	WORD_DATA	CRC
----------	-----------------	---------	---------	-----------	-----------	-----

#### Response sequence in case the tag is in the ID state or meeting selection criteria

Return Preamble	ID	CRC
-----------------	----	-----

**11.2.13 GROUP\_UNSELECT\_EQ\_FLAGS**

When receiving a GROUP\_UNSELECT\_EQ\_FLAGS command, a tag which is in the ID state compares the FLAGS with the BYTE\_DATA sent by the interrogator. In case the FLAGS are equal to BYTE\_DATA the tag goes into the state READY and will not reply. In case the comparison fails, the tag sets its internal counter COUNT to logic 0, reads its UID, sends back the UID and stays in the state ID.

In all other cases the tag will not send any reply.

**Command sequence**

Preamble	Start Delimiter	Command	ADDRESS	BYTE_MASK	WORD_DATA	CRC
----------	-----------------	---------	---------	-----------	-----------	-----

**Response sequence in case of non meeting unselection criteria**

Return Preamble	ID	CRC
-----------------	----	-----

**11.2.14 GROUP\_UNSELECT\_NE\_FLAGS**

When receiving a GROUP\_UNSELECT\_NE\_FLAGS command, a tag which is in the ID state compares the FLAGS with the BYTE\_DATA sent by the interrogator. In case the FLAGS are not equal to BYTE\_DATA the tag goes into the state READY and will not reply. In case the comparison fails, the tag sets its internal counter COUNT to logic 0, reads its UID, sends back the UID and stays in the state ID.

In all other cases the tag will not send any reply.

**Command sequence**

Preamble	Start Delimiter	Command	ADDRESS	BYTE_MASK	WORD_DATA	CRC
----------	-----------------	---------	---------	-----------	-----------	-----

**Response sequence in case of non meeting unselection criteria**

Return Preamble	ID	CRC
-----------------	----	-----

### 11.3 Identification commands

Identification commands are used to run the multiple tag identification protocol.

#### 11.3.1 FAIL

The identification algorithm uses FAIL when more than one tag tried to identify itself at the same time. Some tags back off and some tags retransmit.

In case its internal counter COUNT is not zero or the random generator result is '1', then COUNT shall be increased by '1', unless it is FFh.

If the resulting COUNT value is '0', then the tag reads its UID and sends it back.

##### Command sequence

Preamble	Start Delimiter	Command	CRC
----------	-----------------	---------	-----

##### Response sequence in case of COUNT equals zero

Return Preamble	ID	CRC
-----------------	----	-----

#### 11.3.2 SUCCESS

SUCCESS initiates identification of the next set of tags. It is used in two cases:

- When all tags receiving FAIL backed off and did not transmit, SUCCESS causes those same tags to transmit again.
- After any read or write command moved an identified tag to DATA\_EXCHANGE, SUCCESS causes the next subset of selected but unidentified tags to transmit.

In case its internal counter COUNT is not zero, it will be decreased by '1'.

If the resulting COUNT value is '0', then the tag reads its UID and sends it back.

##### Command sequence

Preamble	Start Delimiter	Command	CRC
----------	-----------------	---------	-----

##### Response sequence in case of COUNT equals zero

Return Preamble	ID	CRC
-----------------	----	-----

### 11.3.3 RESEND

The identification algorithm uses RESEND when only one tag transmitted but the UID was received in error. The tag that transmitted resends its UID.

If the COUNT value is '0', then the tag reads its UID and sends it back.

#### Command sequence

Preamble	Start Delimiter	Command	CRC
----------	-----------------	---------	-----

#### Response sequence in case of COUNTER equals zero

Return Preamble	ID	CRC
-----------------	----	-----

### 11.3.4 INITIALIZE

When receiving an INITIALIZE command a tag goes into the READY state and resets the Data\_Exchange Status Bit.

The tag will not send any response.

#### Command sequence

Preamble	Start Delimiter	Command	CRC
----------	-----------------	---------	-----

## 11.4 Data Transfer commands

Data Transfer commands are used to read or write data from or to the memory.

### 11.4.1 READ

When receiving the READ command, a tag which is any powered state compares the sent ID with its UID. In case the ID is equal to the UID, the tag moves to the DATA\_EXCHANGE state, reads the 8 byte memory content beginning at the specified ADDRESS and sends back its content in the response.

Further, the tag marks the byte at ADDRESS lockable in the lockable state machine.

In all other cases the tag will not send any reply.

#### Command sequence

Preamble	Start Delimiter	Command	ID	ADDRESS	CRC
----------	-----------------	---------	----	---------	-----

#### Response sequence in case of matching UID

Return Preamble	WORD_DATA	CRC
-----------------	-----------	-----

### 11.4.2 READ\_VARIABLE

When receiving the READ\_VARIABLE command, a tag which is in any powered state compares the sent ID with its UID. In case the ID is equal to the UID, the tag moves to the DATA\_EXCHANGE state, reads as many bytes as specified in BYTE\_MASK of the memory content beginning at the specified ADDRESS and sends back its content in the response.

The number given in BYTE\_MASK is one less than the number of 8byte-blocks that will be transmitted.

EXAMPLE A value of '06' in the BYTE\_MASK field requests to send seven 8byte-blocks.

In all other cases the tag will not send any reply.

#### Command sequence

Preamble	Start Delimiter	Command	ID	ADDRESS	LENGTH	CRC
----------	-----------------	---------	----	---------	--------	-----

#### Response sequence in case of matching UID

Return Preamble	VARIABLE_DATA	CRC
-----------------	---------------	-----

Note: Also in case the command uses a valid value for ADDRESS, but the number of bytes read by the command exceed address 'DFh' the command will be executed. However, the content of the addresses exceeding 'DFh' is not defined.

### 11.4.3 DATA\_READ

When receiving the DATA\_READ command, a tag which is in the ID or DATA\_EXCHANGE state compares the sent ID with its UID. In case the ID is equal to the UID, the tag moves to the DATA\_EXCHANGE state, reads the 8 byte memory content beginning at the specified ADDRESS and sends back its content in the response.

Further the tag marks the byte at ADDRESS lockable in the lockable state machine.

In all other cases the tag will not send any reply.

#### Command sequence

Preamble	Start Delimiter	Command	ID	ADDRESS	CRC
----------	-----------------	---------	----	---------	-----

#### Response sequence in case of matching UID

Return Preamble	WORD_DATA	CRC
-----------------	-----------	-----

#### 11.4.4 READ\_VERIFY

When receiving the READ\_VERIFY command, the tag compares the sent ID with its UID. In case the ID is equal to the UID and the WRITE\_OK flag is set, the tag moves to the DATA\_EXCHANGE state, reads the 1-byte memory content at the specified address and sends back its content in the response.

Further, the tag marks the byte at ADDRESS lockable in the lockable state machine.

In all other cases the tag will not send any reply.

##### Command sequence

Preamble	Start Delimiter	Command	ID	ADDRESS	CRC
----------	-----------------	---------	----	---------	-----

##### Response sequence in case of matching UID and WRITE\_OK

Return Preamble	BYTE_DATA	CRC
-----------------	-----------	-----

#### 11.4.5 READ\_VERIFY\_4BYTES

When receiving the READ\_VERIFY\_4BYTE command, the tag compares the sent ID with its UID. In case the ID is equal to the UID and the WRITE\_OK flag is set, the tag moves to the DATA\_EXCHANGE state, reads the 4-byte memory content at the specified address and send back its content in the response.

In all other cases the tag will not send any reply.

BYTE\_MASK of the command

ADDRESSbit of BYTE\_MASK to select whether byte should be written

[ADDRESS+0]B7

[ADDRESS+1]B6

[ADDRESS+2]B5

[ADDRESS+3]B4

##### Command sequence

Preamble	Start Delimiter	Command	ID	ADDRESS	CRC
----------	-----------------	---------	----	---------	-----

##### Response sequence in case of matching UID and WRITE\_OK

Return Preamble	4BYTE_DATA	CRC
-----------------	------------	-----

### 11.4.6 READ\_PORT

When receiving the READ\_PORT command, a tag which is in any powered state tag compares the sent ID with its UID. In case the ID is equal to the UID, the tag moves to the DATA\_EXCHANGE state and reads the 8-bit memory content beginning at the specified port-address and sends back its content in the response.

**Table 27. READ\_PORT**

	Bit8(MSB)	Bit7	Bit6	Bit5	Bit4	Bit3	Bit2	Bit1(LSB)
Port0	RFU	RFU	RFU	RFU	RFU	RFU	write_ok	DE_SB
Port1	RFU	RFU	RFU	RFU	RFU	RFU	RFU	RFU
...	RFU	RFU	RFU	RFU	RFU	RFU	RFU	RFU

[1] RFU ... default 0

In all other cases the tag will not send any reply.

#### Command sequence

Preamble	Start Delimiter	Command	ID	ADDRESS	CRC
----------	-----------------	---------	----	---------	-----

#### Response sequence in case of matching UID

Return Preamble	BYTE_DATA	CRC
-----------------	-----------	-----

See [Section 11.4.13 "Exception handling for fast return link mode"](#) for a special return link behaviour if the 4x STDEL is used.

### 11.4.7 WRITE

When receiving the WRITE command, the tag compares the sent ID with its UID. In case the ID is equal to the UID, the tag moves to the DATA\_EXCHANGE state, reads the lock information for the byte on the specified memory content beginning at the specified address. In case the memory is locked, it sends back the ERROR response. In case of unlocked, it sends back ACKNOWLEDGE and program the data into the specified memory address.

In case the write access was successful, the tag sets the WRITE\_OK bit. Otherwise, it will reset it.

Further the tag marks the byte at ADDRESS lockable in the lockable state machine.

In all other cases the tag will not send any reply.

#### Command sequence

Preamble	Start Delimiter	Command	ID	ADDRESS	BYTE_DATA	CRC	WAIT
----------	-----------------	---------	----	---------	-----------	-----	------

#### Response sequence in case of matching UID but locked byte

Return Preamble	ERROR	CRC
-----------------	-------	-----

#### Response sequence in case of matching UID and unlocked byte

Return Preamble	ACKNOWLEDGE	CRC	EEPROM programming process
-----------------	-------------	-----	----------------------------

See [Section 11.4.13 "Exception handling for fast return link mode"](#) for a special return link behaviour if the 4x STDEL is used.



### 11.4.8 WRITE4BYTE

When receiving the WRITE4BYTE command, the tag compares the sent ID with its UID. In case the ID is equal to the UID, the tag moves to the DATA\_EXCHANGE state, reads the lock information for the 4 bytes of the specified memory content beginning at the specified address. In case one of byte of the memory is locked, it sends back the ERROR response. In case unlocked, it sends back the ACKNOWLEDGE and programs the data into the specified memory. After WRITE4BYTE the LOCK and non of the written memory areas is prepared for locking.

Executing WRITE4BYTE, a tag only writes those bytes that are selected by the BYTE\_MASK.

In case the write access was successful, the tag sets the WRITE\_OK bit. Otherwise, it resets it.

The starting address for the WRITE4BYTE command must be on a 4-byte page boundary.

BYTE\_MASK of the command

ADDRESS	bit of BYTE_MASK to select whether byte should be written
[ADDRESS+0]	B7
[ADDRESS+1]	B6
[ADDRESS+2]	B5
[ADDRESS+3]	B4

#### Command sequence

Preamble	Start Delimiter	Command	ID	ADDRESS	BYTE_MASK	BYTE_DATA	CRC	WAIT
----------	-----------------	---------	----	---------	-----------	-----------	-----	------

#### Response sequence in case of matching UID but locked byte

Return Preamble	ERROR	CRC
-----------------	-------	-----

#### Response sequence in case of matching UID and bytes unlocked

Return Preamble	ACKNOWLEDGE	CRC	EEPROM programming process
-----------------	-------------	-----	----------------------------

See [Section 11.4.13 "Exception handling for fast return link mode"](#) for a special return link behaviour if the 4x STDEL is used.

### 11.4.9 LOCK

When receiving a LOCK command, a tag which is in the DATA\_EXCHANGE state reads its UID and compares it with the ID sent by the interrogator. In case the UID is equal to ID, the ADDRESS is within the valid address range and the byte at ADDRESS is marked lockable, then the tag sends back an ACKNOWLEDGE and programs the lock bit of the specified memory address. In case the ADDRESS is not in the valid address range, or it is not marked as lockable, then the tag sends back the ACKNOWLEDGE\_NOK.

In all other cases the tag will not send any reply.

In case the write access was successful, the tag sets the WRITE\_OK bit. Otherwise, it resets it.

#### Command sequence

Preamble	Start Delimiter	Command	ID	ADDRESS	BYTE_MASK	BYTE_DATA	CRC	WAIT
----------	-----------------	---------	----	---------	-----------	-----------	-----	------

#### Response sequence in case of matching UID and lockable byte

Return Preamble	ERROR	CRC
-----------------	-------	-----

#### Response sequence in case of matching UID but unlockable byte

Return Preamble	ACKNOWLEDGE	CRC	EEPROM programming process
-----------------	-------------	-----	----------------------------

See [Section 11.4.13 "Exception handling for fast return link mode"](#) for a special return link behaviour if the 4x STDEL is used.

### 11.4.10 QUERY\_LOCK

When receiving a QUERY\_LOCK command, a tag reads its UID and compares it with the ID sent by the interrogator. In case the UID is equal to ID the tag moves into the DATA\_EXCHANGE state. Further, the tag reads the lock bit for the memory byte at ADDRESS. In case the memory is not locked, then it responds ACKNOWLEDGE\_OK if WRITE\_OK is set and ACKNOWLEDGE\_NOK if WRITE\_OK is cleared. In case that this memory is locked, then it responds ERROR\_OK if WRITE\_OK is set and ERROR\_NOK if WRITE\_OK is cleared.

Further, the tag marks the byte at ADDRESS lockable in the lockable state machine.

In all other cases the tag will not send any reply.

#### Command sequence

Preamble	Start Delimiter	Command	ID	ADDRESS	CRC
----------	-----------------	---------	----	---------	-----

#### Response sequence in case of matching UID, WRITE\_OK set and unlocked byte

Return Preamble	ACKNOWLEDGE_OK	CRC
-----------------	----------------	-----

#### Response sequence in case of matching UID, WRITE\_OK cleared and unlocked byte

Return Preamble	ACKNOWLEDGE_NOK	CRC
-----------------	-----------------	-----

#### Response sequence in case of matching UID, WRITE\_OK set and locked byte

Return Preamble	ERROR_OK	CRC
-----------------	----------	-----

#### Response sequence in case of matching UID, WRITE\_OK cleared and locked byte

Return Preamble	ERROR_NOK	CRC
-----------------	-----------	-----

See [Section 11.4.13 "Exception handling for fast return link mode"](#) for a special return link behaviour if the 4x STDEL is used.

### 11.4.11 WRITE\_MULTIPLE

This command is used to write to and to verify multiple tags in parallel.

When receiving the WRITE\_MULTIPLE command, a tag which is in the ID state or the DATA\_EXCHANGE state reads the lock information for the byte on the specified memory content beginning at the specified ADDRESS. In case the memory is locked, it does nothing. In case unlocked, it programs the BYTE\_DATA into the specified memory.

In case the write access was successful, the tag sets the WRITE\_OK bit. Otherwise, it resets it.

The tag will not send any response.

**Remark:** As there is not tag response following this command, the 1 x STDEL has to be used

#### Command sequence

Preamble	Start Delimiter	Command	ADDRESS	BYTE_DATA	CRC	WAIT
----------	-----------------	---------	---------	-----------	-----	------

### 11.4.12 WRITE4BYTE\_MULTIPLE

This command is used to write to and to verify multiple tags in parallel.

When receiving the WRITE4BYTE\_MULTIPLE command, a tag which is in the ID state or the DATA\_EXCHANGE state reads the lock information for the byte on the specified memory content beginning at the specified ADDRESS. In case the memory is locked, it does nothing. In case unlocked, it programs the BYTE\_DATA into the specified memory.

Executing WRITE4BYTE\_MULTIPLE a tag only writes those bytes that are selected by the BYTE\_MASK.

In case the write access was successful, the tag sets the WRITE\_OK bit. Otherwise, it resets it.

The starting address for the WRITE4BYTE\_MULTIPLE command must be on a 4-byte page boundary.

The tag will not send any response.

BYTE\_MASK of the command:

ADDRESS	bit of BYTE_MASK to select whether byte should be written
[ADDRESS+0]	B7
[ADDRESS+1]	B6
[ADDRESS+2]	B5
[ADDRESS+3]	B4

**Remark:** As there is not tag response following this command, the 1 x STDEL has to be used

#### Command sequence

Preamble	Start Delimiter	Command	ADDRESS	BYTE_MASK	4BYTE_DATA	CRC	WAIT
----------	-----------------	---------	---------	-----------	------------	-----	------

### 11.4.13 Exception handling for fast return link mode

If "11 01 11 00 10 1" is used as Start Delimiter in the forward link to use the high return link datarate (4 times the forward link datarate) the following deviations have to be considered:

Within the responses of the tag (Acknowledge, Acknowledge\_NOK, Acknowledge\_OK, Error\_NOK, Error, Error\_OK) to the following commands: WRITE, WRITE4BYTE, LOCK, QUERY\_LOCK the data byte returned by the tag does not contain the information used for CRC calculation. Therefore it shall be ignored and only the CRC should be evaluated. The exact meaning of the returned information is described in [Table 28](#).

**Table 28. Tag responses in the 4x return link mode**

Response name	Response size/byte		Transmitted Value	
	Data	CRC	Data	CRC
ACKNOWLEDGE	1	2	XX hex	1E0F hex
ACKNOWLEDGE_NOK	1	2	XX hex	1E0F hex
ACKNOWLEDGE_OK	1	2	XX hex	0E2E hex
ERROR_NOK	1	2	XX hex	00FF hex
ERROR	1	2	XX hex	00FF hex
ERROR_OK	1	2	XX hex	10DE hex

If the READ\_PORT command is used together with start delimiter "11 01 11 00 10 1" the data has to be evaluated as described in [Table 29](#).

**Table 29. Tag responses in the 4x return link mode for the READ\_PORT command**

Response name	Response size / byte		Transmitted Value	
	Data	CRC	Data	CRC
Port 0	cleared	cleared	XX hex	1E0F hex
	cleared	set	XX hex	0E2E hex
	set	cleared	XX hex	3E4D hex
	set	set	XX hex	2E6C hex
Port 1 - 255	seX	X	XX hex	1E0F hex

**Remark:** X in the tag state column indicates a don't care value. XX hex in the transmitted value column indicates that this data do not carry any useful respond information.

This table only described the support of the flags WRITE\_OK flag, DE\_SB flag. All other flags are not used by this device and are set to 0.

## 12. Limiting values

Please refer to [Ref. 7 "Data sheet addendum"](#).

## 13. Characteristics

### 13.1 DC characteristics

**Table 30. DC characteristics**

$V_{DD} > V_{DDmin}$ ;  $V_{SS} = 0$  V;  $T_{amb} = -40$  to  $85$  °C; all voltages with respect to  $V_{SS}$  unless otherwise specified.

Symbol	Parameter	Conditions	Min	Max	Unit
$V_{RFP, min}$	minimum supply voltage range for communication except EEPROM programming		[1] 1.15	1.55	V
$V_{RFP, write}$	minimum supply voltage for EEPROM programming		[1] 2.10	2.40	V

[1] The measured operating voltage is the open-circuit voltage of a source with a  $50 \Omega$  output impedance.

### 13.2 AC characteristics

**Table 31. AC characteristics**

$V_{DD} > V_{DDmin}$ ;  $V_{SS} = 0$  V;  $T_{amb} = -40$  to  $85$  °C; all voltages with respect to  $V_{SS}$  unless otherwise specified.

Symbol	Parameter	Conditions	Min	Max	Unit
$t_{DE\_SB}$	Storage time for Data_Exchange Status Bit	IC temperature: 0 to 50 °C	4	-	s
		IC temperature: -30 °C to 60 °C	2	-	s
$t_{EEwrite}$	Required time for programming the EEPROM		13.3	-	ms
$t_{EEwrite}$	Power interruptions, no notice		-	0.5	$\mu$ s
$t_{SD}$	Power interruptions, start of demodulation		0.5	250	$\mu$ s

## 14. Package outline

Please refer to [Ref. 7 "Data sheet addendum"](#).

## 15. Abbreviations

**Table 32. Abbreviations**

Acronym	Description
ID	Tag identification number sent by the interrogator
UID	Unique Tag identification number stored in the tag
Forward link	Transmitted data from the interrogator to the tag
Return link	Transmitted data from the tag to the interrogator
CRC	Cyclic Redundancy Check
EEPROM	Electrically Erasable and Programmable Read Only Memory
xxh	Value in hexadecimal notation
IC	Integrated Circuit
LSB	Least Significant Bit or Byte
MSB	Most Significant Bit or Byte
RF	Radio Frequency
NRZ	Non-return to zero coding
FMO	Bi phase space modulation

## 16. References

- [1] [CEPT1] — CEPT REC 70-03 Annex 1
- [2] [CEPT1] — CEPT REC 70-03 Annex 1
- [3] [CEPT2] — CEPT REC 70-03 Annex 11
- [4] [ETSI1] — ETSI EN 330 220-1
- [5] [ETSI2] — ETSI EN 330 440-1
- [6] [FCC1] — FCC Part 15 Section 247
- [7] **Data sheet addendum** — *SL3ICS3001 Bumped Wafer Specification*, document number: 0707\*\*1

1. \*\* ... document version number

## 17. Revision history

**Table 33. Revision history**

Document ID	Release date	Data sheet status	Change notice	Supersedes
SL3ICS3001_072831 v. 3.1	20120709	Product data sheet	-	SL3ICS3001_072831 v. 3.0
Modifications:	<ul style="list-style-type: none"> <li>• <a href="#">Table 2 "Ordering information"</a>: Type number changed into SL3ICS3001FW/V7</li> </ul>			
SL3ICS3001_072831 v. 3.0	20090702	Product data sheet		072820
Modifications:	<ul style="list-style-type: none"> <li>• The format of this data sheet has been redesigned to comply with the new identity guidelines of NXP Semiconductors.</li> <li>• Legal texts have been adapted to the new company name where appropriate.</li> <li>• Change of product status.</li> <li>• <a href="#">Section 3 "Applications"</a> and <a href="#">Section 4 "Ordering information"</a>: added</li> </ul>			
072820	September 2003	Objective data sheet		072811
	<ul style="list-style-type: none"> <li>• Update</li> </ul>			
072811	April 2003	Objective data sheet		072810
	<ul style="list-style-type: none"> <li>• Update</li> </ul>			
072810	June 2002	Objective data sheet		



## 18. Legal information

### 18.1 Data sheet status

Document status <sup>[1][2]</sup>	Product status <sup>[3]</sup>	Definition
Objective [short] data sheet	Development	This document contains data from the objective specification for product development.
Preliminary [short] data sheet	Qualification	This document contains data from the preliminary specification.
Product [short] data sheet	Production	This document contains the product specification.

[1] Please consult the most recently issued document before initiating or completing a design.

[2] The term 'short data sheet' is explained in section "Definitions".

[3] The product status of device(s) described in this document may have changed since this document was published and may differ in case of multiple devices. The latest product status information is available on the Internet at URL <http://www.nxp.com>.

### 18.2 Definitions

**Draft** — The document is a draft version only. The content is still under internal review and subject to formal approval, which may result in modifications or additions. NXP Semiconductors does not give any representations or warranties as to the accuracy or completeness of information included herein and shall have no liability for the consequences of use of such information.

**Short data sheet** — A short data sheet is an extract from a full data sheet with the same product type number(s) and title. A short data sheet is intended for quick reference only and should not be relied upon to contain detailed and full information. For detailed and full information see the relevant full data sheet, which is available on request via the local NXP Semiconductors sales office. In case of any inconsistency or conflict with the short data sheet, the full data sheet shall prevail.

**Product specification** — The information and data provided in a Product data sheet shall define the specification of the product as agreed between NXP Semiconductors and its customer, unless NXP Semiconductors and customer have explicitly agreed otherwise in writing. In no event however, shall an agreement be valid in which the NXP Semiconductors product is deemed to offer functions and qualities beyond those described in the Product data sheet.

### 18.3 Disclaimers

**Limited warranty and liability** — Information in this document is believed to be accurate and reliable. However, NXP Semiconductors does not give any representations or warranties, expressed or implied, as to the accuracy or completeness of such information and shall have no liability for the consequences of use of such information. NXP Semiconductors takes no responsibility for the content in this document if provided by an information source outside of NXP Semiconductors.

In no event shall NXP Semiconductors be liable for any indirect, incidental, punitive, special or consequential damages (including - without limitation - lost profits, lost savings, business interruption, costs related to the removal or replacement of any products or rework charges) whether or not such damages are based on tort (including negligence), warranty, breach of contract or any other legal theory.

Notwithstanding any damages that customer might incur for any reason whatsoever, NXP Semiconductors' aggregate and cumulative liability towards customer for the products described herein shall be limited in accordance with the *Terms and conditions of commercial sale* of NXP Semiconductors.

**Right to make changes** — NXP Semiconductors reserves the right to make changes to information published in this document, including without limitation specifications and product descriptions, at any time and without notice. This document supersedes and replaces all information supplied prior to the publication hereof.

**Suitability for use** — NXP Semiconductors products are not designed, authorized or warranted to be suitable for use in life support, life-critical or safety-critical systems or equipment, nor in applications where failure or malfunction of an NXP Semiconductors product can reasonably be expected to result in personal injury, death or severe property or environmental damage. NXP Semiconductors and its suppliers accept no liability for inclusion and/or use of NXP Semiconductors products in such equipment or applications and therefore such inclusion and/or use is at the customer's own risk.

**Applications** — Applications that are described herein for any of these products are for illustrative purposes only. NXP Semiconductors makes no representation or warranty that such applications will be suitable for the specified use without further testing or modification.

Customers are responsible for the design and operation of their applications and products using NXP Semiconductors products, and NXP Semiconductors accepts no liability for any assistance with applications or customer product design. It is customer's sole responsibility to determine whether the NXP Semiconductors product is suitable and fit for the customer's applications and products planned, as well as for the planned application and use of customer's third party customer(s). Customers should provide appropriate design and operating safeguards to minimize the risks associated with their applications and products.

NXP Semiconductors does not accept any liability related to any default, damage, costs or problem which is based on any weakness or default in the customer's applications or products, or the application or use by customer's third party customer(s). Customer is responsible for doing all necessary testing for the customer's applications and products using NXP Semiconductors products in order to avoid a default of the applications and the products or of the application or use by customer's third party customer(s). NXP does not accept any liability in this respect.

**Limiting values** — Stress above one or more limiting values (as defined in the Absolute Maximum Ratings System of IEC 60134) will cause permanent damage to the device. Limiting values are stress ratings only and (proper) operation of the device at these or any other conditions above those given in the Recommended operating conditions section (if present) or the Characteristics sections of this document is not warranted. Constant or repeated exposure to limiting values will permanently and irreversibly affect the quality and reliability of the device.

**Terms and conditions of commercial sale** — NXP Semiconductors products are sold subject to the general terms and conditions of commercial sale, as published at <http://www.nxp.com/profile/terms>, unless otherwise agreed in a valid written individual agreement. In case an individual agreement is concluded only the terms and conditions of the respective agreement shall apply. NXP Semiconductors hereby expressly objects to applying the customer's general terms and conditions with regard to the purchase of NXP Semiconductors products by customer.

**No offer to sell or license** — Nothing in this document may be interpreted or construed as an offer to sell products that is open for acceptance or the grant, conveyance or implication of any license under any copyrights, patents or other industrial or intellectual property rights.

**Export control** — This document as well as the item(s) described herein may be subject to export control regulations. Export might require a prior authorization from competent authorities.

**Quick reference data** — The Quick reference data is an extract of the product data given in the Limiting values and Characteristics sections of this document, and as such is not complete, exhaustive or legally binding.

**Non-automotive qualified products** — Unless this data sheet expressly states that this specific NXP Semiconductors product is automotive qualified, the product is not suitable for automotive use. It is neither qualified nor tested in accordance with automotive testing or application requirements. NXP Semiconductors accepts no liability for inclusion and/or use of non-automotive qualified products in automotive equipment or applications.

In the event that customer uses the product for design-in and use in automotive applications to automotive specifications and standards, customer (a) shall use the product without NXP Semiconductors' warranty of the product for such automotive applications, use and specifications, and (b)

whenever customer uses the product for automotive applications beyond NXP Semiconductors' specifications such use shall be solely at customer's own risk, and (c) customer fully indemnifies NXP Semiconductors for any liability, damages or failed product claims resulting from customer design and use of the product for automotive applications beyond NXP Semiconductors' standard warranty and NXP Semiconductors' product specifications.

**Translations** — A non-English (translated) version of a document is for reference only. The English version shall prevail in case of any discrepancy between the translated and English versions.

## 18.4 Trademarks

Notice: All referenced brands, product names, service names and trademarks are the property of their respective owners.

**UCODE** — is a trademark of NXP B.V.

## 19. Contact information

For more information, please visit: <http://www.nxp.com>

For sales office addresses, please send an email to: [salesaddresses@nxp.com](mailto:salesaddresses@nxp.com)

## 20. Tables

Table 1.	Operating distances for UCODE HSL based tags and labels in released frequency bands . . . . .	3
Table 2.	Ordering information . . . . .	4
Table 3.	Released operating frequency bands . . . . .	6
Table 4.	Command Overview . . . . .	9
Table 5.	State transition table . . . . .	10
Table 6.	Flags . . . . .	11
Table 7.	Definition of forward PREAMBLE . . . . .	14
Table 8.	Definition of START DELIMITER . . . . .	14
Table 9.	Definition of forward RETURN PREAMBLE . . . . .	15
Table 10.	CRC definition . . . . .	16
Table 11.	Practical example of CRC calculation for a 'SUCCESS' command in the Interrogator . . . . .	17
Table 12.	Practical example of CRC checking for a 'SUCCESS' command in the Tag . . . . .	17
Table 13.	Definition of TAG RESYNC . . . . .	18
Table 14.	Forward data rate . . . . .	18
Table 15.	Modulation Type 18 % - Parameters for the RF envelop shape . . . . .	19
Table 16.	Modulation Type 100% - Parameters for the RF envelop shape . . . . .	19
Table 17.	Bit duty cycle tolerance . . . . .	20
Table 18.	Return data rate . . . . .	20
Table 19.	Bit duty cycle tolerance . . . . .	20
Table 20.	Maximum interrogator settling time . . . . .	21
Table 21.	Timing limits . . . . .	22
Table 22.	Tag reaction on power interruptions . . . . .	22
Table 23.	Configuration of delivered ICs . . . . .	23
Table 24.	Command codes and format . . . . .	24
Table 25.	Command fields . . . . .	25
Table 26.	Tag response . . . . .	25
Table 27.	READ_PORT . . . . .	39
Table 28.	Tag responses in the 4x return link mode . . . . .	45
Table 29.	Tag responses in the 4x return link mode for the READ_PORT command . . . . .	45
Table 30.	DC characteristics . . . . .	46
Table 31.	AC characteristics . . . . .	46
Table 32.	Abbreviations . . . . .	47
Table 33.	Revision history . . . . .	48

## 21. Figures

---

Fig 1.	Block diagram	5
Fig 2.	State diagram	7
Fig 3.	Example of a forward link sequence	14
Fig 4.	Example of a return link sequence	15
Fig 5.	Example for bit and byte ordering for the GROUP_SELECT command	15
Fig 6.	Definition of the RF envelope in the forward link	19
Fig 7.	Example of a 100% modulation	20
Fig 8.	Example of a 15% modulation	20
Fig 9.	Definition of a Manchester '0'	21
Fig 10.	Definition of a Manchester '1'	21
Fig 11.	RF envelope - power up waveform	22

## 22. Contents

<b>1</b>	<b>General description</b> . . . . .	<b>1</b>	9.2.2	Modulation Waveform of Transponder Modulation . . . . .	20
<b>2</b>	<b>Features and benefits</b> . . . . .	<b>2</b>	9.3	Bit Coding . . . . .	21
2.1	RF interface features . . . . .	2	9.3.1	Forward Link . . . . .	21
2.2	Memory features . . . . .	2	9.3.2	Return Link . . . . .	21
2.3	Security features . . . . .	2	9.4	Response Time . . . . .	21
2.4	Operating distances features . . . . .	2	9.5	Regeneration Time . . . . .	21
2.5	Air interface standards . . . . .	4	9.6	Start-up Time . . . . .	22
2.6	Application standards . . . . .	4	9.7	Power interruptions . . . . .	22
<b>3</b>	<b>Applications</b> . . . . .	<b>4</b>	<b>10</b>	<b>Memory</b> . . . . .	<b>23</b>
<b>4</b>	<b>Ordering information</b> . . . . .	<b>4</b>	10.1	Memory organization . . . . .	23
<b>5</b>	<b>Block diagram</b> . . . . .	<b>5</b>	10.2	Definition of block contents . . . . .	23
<b>6</b>	<b>Pinning information</b> . . . . .	<b>5</b>	10.2.1	UID . . . . .	23
<b>7</b>	<b>Functional description</b> . . . . .	<b>6</b>	10.3	Configuration of delivered ICs . . . . .	23
7.1	Power transfer . . . . .	6	<b>11</b>	<b>Commands</b> . . . . .	<b>24</b>
7.2	Operation frequency . . . . .	6	11.1	Definitions . . . . .	24
7.3	Data transfer . . . . .	6	11.2	Selection commands . . . . .	26
7.3.1	Forward link . . . . .	6	11.2.1	Data comparison for selection commands . . . . .	26
7.3.2	Return link . . . . .	6	11.2.1.1	Data comparison for selection commands on memory . . . . .	26
<b>8</b>	<b>Protocol</b> . . . . .	<b>7</b>		The argument of the comparison are: . . . . .	26
8.1	Major digital states . . . . .	7		and the argument of the command: . . . . .	26
	State transition description . . . . .	8		The argument BYTE_MASK defines what bytes to be considered for comparison: . . . . .	27
8.2	Command overview . . . . .	9	11.2.1.2	Data comparison for selection commands on flags . . . . .	27
8.3	Flags . . . . .	11		The argument BYTE_MASK defines what bytes to be considered for comparison: . . . . .	28
8.3.1	Data_Exchange status bit . . . . .	11	11.2.2	GROUP_SELECT_EQ . . . . .	29
8.3.2	WRITE_OK . . . . .	11	11.2.3	GROUP_SELECT_NE . . . . .	29
8.4	Lockable state machine . . . . .	12	11.2.4	GROUP_SELECT_GT . . . . .	30
8.5	Collision arbitration, anticollision . . . . .	12	11.2.5	GROUP_SELECT_LT . . . . .	30
8.6	Data exchange sequences . . . . .	13	11.2.6	GROUP_UNSELECT_EQ . . . . .	31
8.6.1	Forward link . . . . .	13	11.2.7	GROUP_UNSELECT_NE . . . . .	31
8.6.1.1	Preamble . . . . .	14	11.2.8	GROUP_UNSELECT_GT . . . . .	31
8.6.1.2	START DELIMITER . . . . .	14	11.2.9	GROUP_UNSELECT_LT . . . . .	32
8.6.2	Return link . . . . .	14	11.2.10	MULTIPLE_UNSELECT . . . . .	32
8.6.2.1	RETURN PREAMBLE . . . . .	15	11.2.11	GROUP_SELECT_EQ_FLAGS . . . . .	33
8.7	Bit and byte ordering . . . . .	15	11.2.12	GROUP_SELECT_NE_FLAGS . . . . .	33
8.8	Data integrity . . . . .	15	11.2.13	GROUP_UNSELECT_EQ_FLAGS . . . . .	34
8.9	CRC definition . . . . .	16	11.2.14	GROUP_UNSELECT_NE_FLAGS . . . . .	34
8.9.1	CRC algorithm . . . . .	16	11.3	Identification commands . . . . .	35
8.9.2	CRC calculation example . . . . .	16	11.3.1	FAIL . . . . .	35
<b>9</b>	<b>Communication timing and waveforms</b> . . . . .	<b>18</b>	11.3.2	SUCCESS . . . . .	35
9.1	Forward link . . . . .	18	11.3.3	RESEND . . . . .	36
9.1.1	Communication rate . . . . .	18	11.3.4	INITIALIZE . . . . .	36
9.1.2	Modulation Waveform of Interrogator Modulation . . . . .	19	11.4	Data Transfer commands . . . . .	36
9.1.3	RF envelope of data streams . . . . .	20			
9.2	Return link . . . . .	20			
9.2.1	Communication rate . . . . .	20			

continued >>

11.4.1	READ .....	36
11.4.2	READ_VARIABLE .....	37
11.4.3	DATA_READ .....	37
11.4.4	READ_VERIFY .....	38
11.4.5	READ_VERIFY_4BYTES .....	38
11.4.6	READ_PORT .....	39
11.4.7	WRITE .....	40
11.4.8	WRITE4BYTE .....	41
11.4.9	LOCK .....	42
11.4.10	QUERY_LOCK .....	43
11.4.11	WRITE_MULTIPLE .....	44
11.4.12	WRITE4BYTE_MULTIPLE .....	44
11.4.13	Exception handling for fast return link mode. .	45
<b>12</b>	<b>Limiting values. ....</b>	<b>46</b>
<b>13</b>	<b>Characteristics. ....</b>	<b>46</b>
13.1	DC characteristics .....	46
13.2	AC characteristics .....	46
<b>14</b>	<b>Package outline .....</b>	<b>47</b>
<b>15</b>	<b>Abbreviations .....</b>	<b>47</b>
<b>16</b>	<b>References .....</b>	<b>47</b>
<b>17</b>	<b>Revision history .....</b>	<b>48</b>
<b>18</b>	<b>Legal information .....</b>	<b>49</b>
18.1	Data sheet status .....	49
18.2	Definitions .....	49
18.3	Disclaimers .....	49
18.4	Trademarks .....	50
<b>19</b>	<b>Contact information .....</b>	<b>50</b>
<b>20</b>	<b>Tables .....</b>	<b>51</b>
<b>21</b>	<b>Figures .....</b>	<b>52</b>
<b>22</b>	<b>Contents .....</b>	<b>53</b>

Please be aware that important notices concerning this document and the product(s) described herein, have been included in section 'Legal information'.

© NXP B.V. 2012.

All rights reserved.

For more information, please visit: <http://www.nxp.com>

For sales office addresses, please send an email to: [salesaddresses@nxp.com](mailto:salesaddresses@nxp.com)

Date of release: 9 July 2012  
072831